

ADMIXTURE BATCHING SYSTEMS

UIC Universal interface pulse scaling card **with MES, AMM-v2, CMM or KMS flowmeters.**



Congratulations on choosing a **ManuFlo**®™ flowmetered Batching Interface Measurement System.
You will now join many thousands of satisfied customers worldwide.

Your system comprises:



i) MES-P or ii) AMM-v2 or iii) CMM or iv) KMS flowmeters

Information sheets included:

1. UIC Interface Pulse Scaling Card specification & installation datasheet
2. Basic Plumbing Pump Installation Guide
3. Flowmeter Overview + brochure spec (refer chosen flowmeter type)
4. Service / Troubleshooting guide. Also: <http://www.manuelectronics.com.au/technical.html>

Prior to installation:

- A. Consider a good access position for the UIC Interface Card for any future calibration scaling changes in close proximity to the PLC/Computer Control System.

ALWAYS USE pure REGULATED VOLTAGE POWER SUPPLY for the UIC cards.

- B. **i)** When using **MES20/25/32/40 PD-flowmeters**, the **UIC-24VDC** versions will supply +12vdc regulated voltage directly to the flowmeters. (Use the +12VDC rail to power all the flowmeters). When using the **UIC** versions with input power supply of +5-12VDC, the card will output the same proportional voltage to the flowmeter.

ii) When using the **AMM-v2 Mag-flowmeters** they can be powered by +12-24VDC. This allows them to be wired and powered from the UIC's +12VDC or directly from the +24VDC pwr source.

iii) When using with **CMM15/20/25 Mag-flowmeters** they require +24VDC power: Use the **UIC-24VDC** and power it and the **CMM Magflows** with the same +24VDC power source. Make sure the +24vdc power supply can adequately power the **UIC-24VDC** and the **CMM25** Magflows which require 6watts directly. In this case power the Magflows directly and only use the pulse wire and shield (o.v.) wire (2 wires) to connect to **UIC inputs**. (Do not use the +12vdc supply rail).

iv) When using **KMS** DC powered Mag-flowmeters, the same method of connection setup applies as per the CMM mag versions. In this case power the Magflows directly and only use the pulse wire and shield (o.v.) wire (2 wires) to connect to **UIC inputs**.

v) If only 12VDC power supply **UIC** cards are installed then use the **CV12-24** voltage step-up converter to provide +24VDC power to the **CMM** or **KMS** Magflows (as per wiring diagrams).

- C. Install the flowmeter as per the installation guide found on the flowmeter brochure.
D. Use shielded cable only for connection between flowmeters and UIC interface cards.
E. Make sure all flowmeter parameters have been set and calibration taken prior to using.

If unsure on any aspect of installation or operation, call ManuFlo or your local installer.

i) or ii) With UIC Interface Card

The UIC **Universal Interface Card** provides: signal **scaling** and an **isolation interface** to pulse flowmeter outputs, and re-transmits to PLC/computer inputs. Models available: **UIC/A2** = 24-240vac switching or **UIC/D** = 5-30vdc switching.

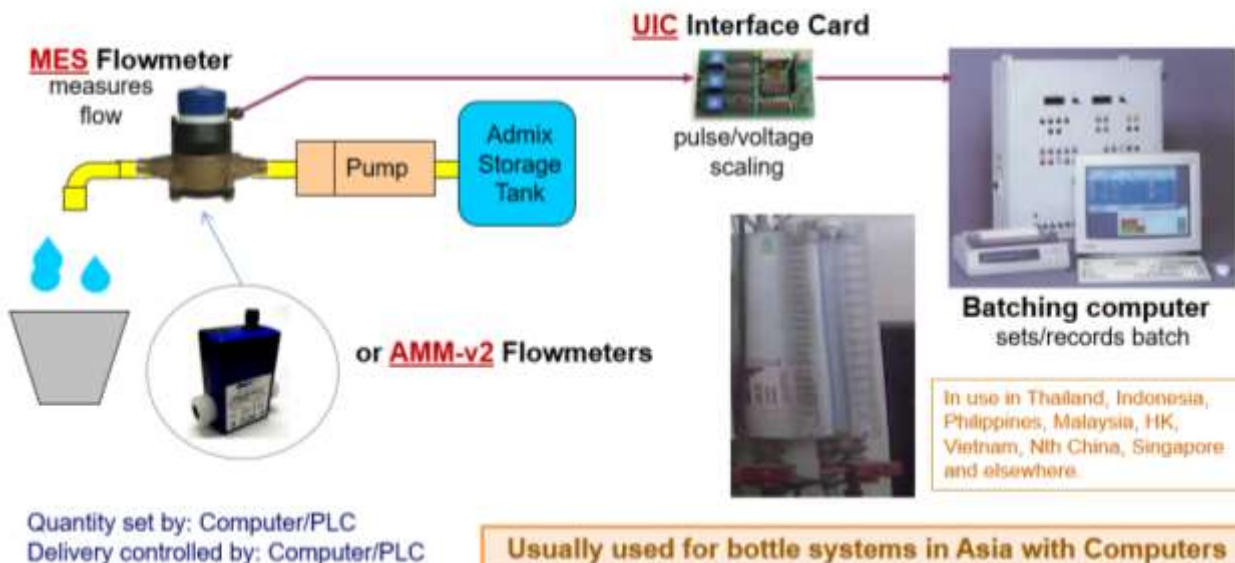

Consult your local systems integrator / admix supplier or ManuFlo for advise.
ManuFlo recommends all non-ManuFlo equipment be sourced locally where possible.
(i.e. Valves, hoses, solenoids, pipe fittings, extended electrical cables etc).
(Suggestion; Visit a batch plant see ManuFlo equipment installed in operation)

ADMIXTURE SYSTEM INSTALL PROCEDURE

- **Prior to commencing installation:** Study the **UIC** and relevant flowmeter specifications, HTU calibration K-Factor setting requirements for the input and subsequent output settings for the flowmeter and PLC inputs and wiring and plumbing diagrams for full understanding.
- Mount the pumps on the stand with the flowmeters and fittings. Wire as per wiring diagrams.
- Protect any external 240vac power cables with channel conduit to protect from electrocution).
- Run the low voltage pulse signal cable (SHIELDED) from the flowmeters up to the **UIC** inputs.



MES20 20mm flowmeters install



KMS502-25F 25mm flowmeters install

GENERAL INSTALLATION GUIDE

with Flowmeters

(1) Locate the most appropriate position to mount the flowmeter (refer to the flowmeters datasheet)
. Preferably:

- your site's flowmeters should be grouped together off the ground on a stand.
- protect the flowmeters from the elements by using a cover, which should be lightweight with handles for easy access by service personnel.
- a vibration free area is recommended, to avoid any stray pulse generations.

Refer to the "Installation" section in the flowmeter datasheet or ManuFlo technical guide:-

<http://www.manuelectronics.com.au/technical.html>.

(2) Establish the outlet point position in relation to the storage tank:

2a) If the outlet point is above the top of the storage tank (the most commonly used setup), then the additional equipment you will need is at least: a pump, non-return valves or spring loaded check valves (12psi), flow restriction gate or ball valve and, optionally:

- a solenoid valve (air-assisted ball valve type) for instant shut off of flow, is recommended to prevent the Venturi effect when injecting into water lines or for Magflows which do not have reverse flow pulse capability.
- a 3-Way Valve to provide an easily accessible calibration point.
- Use 3/4" to 1" (or larger for high volume/ high speed batching applications) pipeline or rigid hose.

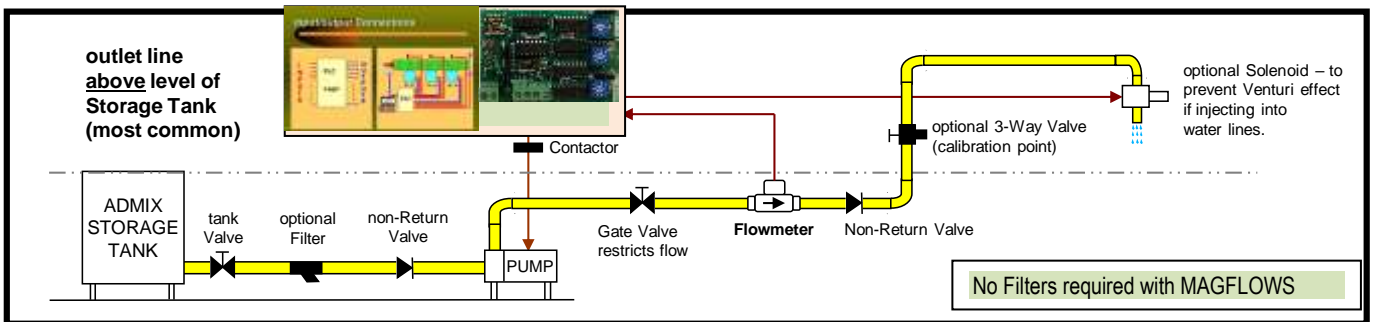

2b) If the outlet point is at the same level as the storage tank, then the equipment you will need is at least: a pump, a flow restriction gate or ball valve, a flowmeter with pulse output, and a solenoid valve to stop free flow.

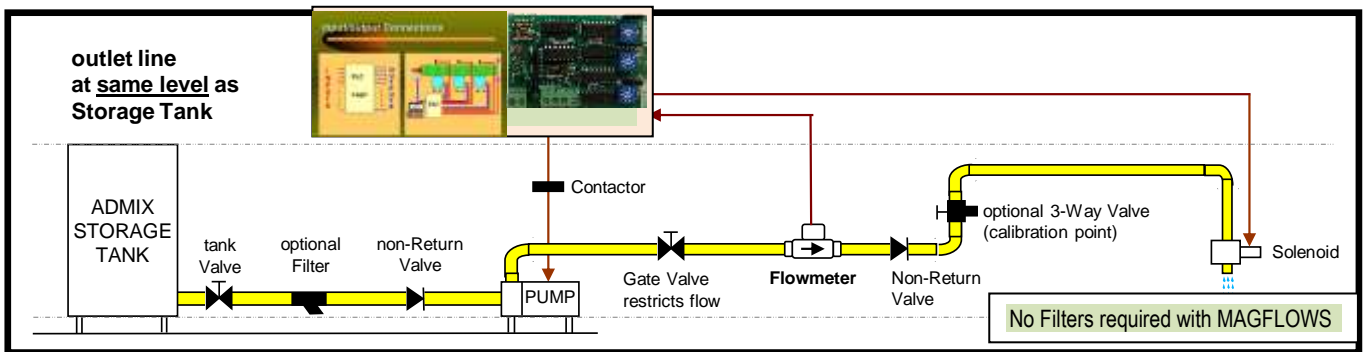

2c) If the outlet point is below the level of the storage tank, then the equipment you will need is at least: a flow control solenoid valve, a flow restriction gate or ball valve, and a flowmeter with pulse output.

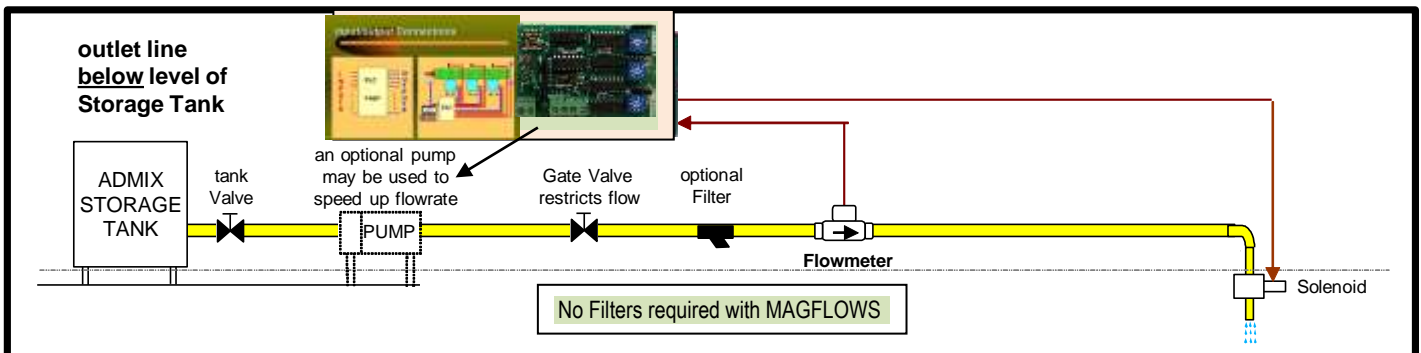

SELECTION OF PIPE LINE DIAMETERS

► For low flowrates and small batch quantities of liquid (approx < 2000mls), use ½" diameter pipe or hose (after the flowmeter). ► For medium to high flowrates, use ¾" to 1" diameter pipe. ► For very high flowrates, use 1¼".

NOTE: Pipeline can be flexible reinforced hose (NOT flexible expandable soft hose), rigid PVC or metallic.

*Warning: Running MES flowmeters over their maximum flow rating may damage them and cause overdosing.
(In any case the ME2008 and ME995 will detect and warn the user)*

PUMP SELECTION (Also refer to PUMP SELECTION page-2)

► When 20mm MES20 flowmeters are used with fluids of specific gravity 1 - 1.25, then use centrifuge pumps of 0.5 - 1 horse power (e.g. 1" Onga-413 or SJ35-04 pumps. When using larger capacity flowmeters, a proportionally larger pump will apply). A flowrate upto 0.8 Litres per second can be achieved, depending on head height. ► For higher density fluids, positive displacement (PD) pumps are more suitable. Because of pressures generated by PD pumps, it is important to be able to restrict the flow – this can be achieved by using an inlet-to-outlet bypass flow valve to recirculate the flow line. (also allows pressure relief to avoid burning pump seals).

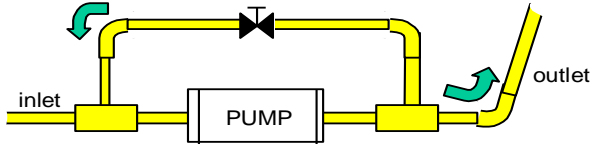

Note: This method of restriction of flow eliminates air being counted by MES flowmeters if the admix storage tank is empty. Also can control pressure and flowrates.

FILTERS

Although MES flowmeters can pass small solids without jamming, a considerable amount of foreign particles can be transferred into admix storage tanks. Therefore, it is advisable to install a box filter prior to positive displacement type flowmeters, to prevent blockage or damage to the flowmeter measuring chamber unit (Amiad™ Ystrainer 800-micron filter is recommended).

No FILTERS required. But Pipe lengths.

Not required with magnetic flowmeters as no moving parts. But allow 5 x dia. on inlet side and 3 x dia. on outlet for AMM-v2/CMM and KMS/RMS larger Magflows of straight pipe of same diameter or larger of the flowmeter bore for flow condition straightening.

COMMISSIONING UIC + flowmeter SYSTEMS

- Determine the most appropriate position to mount the UIC so it will be close proximity to the PC control system inputs and for access to recalibrate/ rescale flowmeter pulse outputs. Make sure the UIC have a value set on the "HTU" dials before powering up. The scaled output pulse must equal the computer input pulse value.
- Electricians must refer to the relevant ManuFlo wiring diagram. Ensure that there is no power to the units before connecting the flowmeter signal cable into the plugs. When wiring the flowmeter, use 2-core shielded cable (use more cores if wiring more flowmeters) - this will allow future expansion, and will transmit pulses from the flowmeter to the UIC cards: 1 wire for pulse, , and the shield as 0 volts return (For 2-wire contact closure flowmeters and electromagnetic flowmeters, do not use 12 volts).
- Connect the applicable power supply voltage to the UIC and flowmeters). For pump applications, a heavy duty contactor (10 Amps for SJ35-04 pump) must be wired into the system. Contactors can be supplied by ManuFlo. Do not use plug-in relays.
- Power up the system. Reset and start a number of times to prime the system, until fluid appears at the outlet line and the Batch Controller digits begin counting.

NOTE: THE OUTPUT PULSE VALUE from the UIC matches the input PULSE setting on the PLC/computer.

A volumetric calibration test should be performed when commissioning a new installation: place a calibrated vessel at the discharge point or before, set a batch quantity on the PLC/Computer, batch the quantity and then check that the delivered quantity is what was requested on the Computer screen and should match on in the volumetric canister.

A calibration check should also be performed periodically (say every 6 months):

If unsure about installation, check the appropriate wiring diagram, product brochure and trouble-shooting guide.

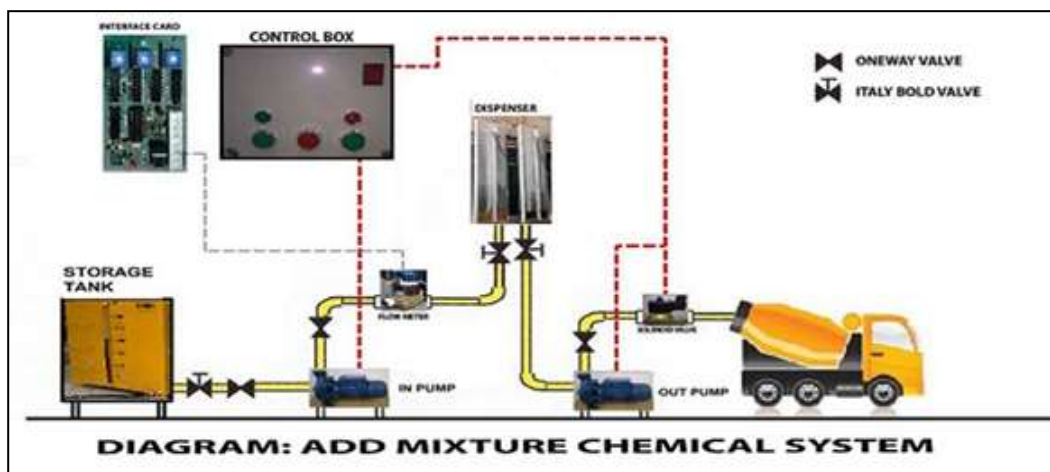

FLOWMETER OVERVIEW STATS.

i) **MES-P** Pulse output flowmeters (-DSP or -DSP-OC) 25+ yrs chamber operating life)^

- Ideal for Admixture Batching applications.
- MES20 has 1 millilitre / 1 pulse output.
- Measures liquids to Specific Gravity 1.4
- Accuracy unaffected by variations in S.G's.
- Nutating disc measuring chamber.
- Small Impurities can pass through
Low hydraulic thrust minimises wear.

- 1000 pulses per litre for 20mm).
- Operates from +4 to 30VDC
- Accuracy: $\pm 1.5\%$, Repeatability: $\pm 0.2\%$
- Supply current: 5 to 25mA Prop to supply volt.
- Temp.50C, Durable gunmetal body, pressure 11bar
- Connection: 20 - 32 mm : threaded BSP (male)
40 mm : flanged BSP (female)



Order Code	Description	Standard Pulses / Litre	Flowrange Litres/min
<u>Digital Pulse Output 4-30VDC</u>			
MES20-NE	20mm NEW compact low profile body & chamber version, 3/4" BSP(m) ends	(1000 ppl)	1.5 - 83
MES25	25mm NEW digital pulse output flowmeter, threaded 1" BSP(m) ends	(555 ppl)	2.7 - 113
MES32	32mm " " " " threaded 1 1/4" BSP(m) ends	(261 ppl)	3.8 - 185
MES40	40mm " " " " flanged 1 1/2" BSP(f) ends	(116 ppl)	7.5 - 375

ii) **AMM-v2** Compact Mini-Mag Flowmeters

- 15mm, 20mm and 25mm sizes. Industrial grade light weight design.
- + 24VDC powered. Mating M12 5pin 3mtr cable lead plug-set included.
- Accuracy. @ $\pm 1.5\%$, 0.3% repeatability, from 50 μ S/cm., Pressure 16bar., Temp. -20 °C to 90 °C
- Peek lined sensor, SS316 probes with integrated earthing. BSP(m) ends..
- Forward direction pulse, Empty Pipe Detection. Unaffected by varying viscosity or SG's of liquids.



Order Code	Description	Pulses / Litre	(Litres/min)
AMM15	1/2" MiniMag (15mm -Bsp(m) connection, 8mm ID bore). pulse output	1000	1 -- 45
AMM20	3/4" MiniMag (20mm -Bsp(m) connection, 12mm ID bore). pulse output.	1000	3 -- 100
AMM25	1" MiniMag (25mm -Bsp(m) connection, 18mm ID bore). pulse output.	500	5 -- 180

iii) **CMM** Compact Mini-Mag Flowmeters

- 15mm, 20mm and 25mm sizes. Industrial grade light weight design.
- + 24VDC powered. Mating M12 5pin 3mtr cable lead plug-set included.
- Accuracy. @ $\pm 1.5\%$, 0.3% repeatability, from 50 μ S/cm., Pressure 16bar., Temp. -20 °C to 90 °C
- Peek lined sensor, SS316 probes with integrated earthing. BSP(m) ends..
- Forward direction pulse, Empty Pipe Detection. Unaffected by varying viscosity or SG's of liquids.



Order Code	Description	Pulses / Litre	(Litres/min)
CMM15	1/2" MiniMag (15mm -Bsp(m) connection, 7mm ID bore). pulse output	1000	0.5 -- 30
CMM20	3/4" MiniMag (20mm -Bsp(m) connection, 10mm ID bore). pulse output.	500	1.0 -- 60
CMM25	1" MiniMag (25mm -Bsp(m) connection, 20mm ID bore). pulse output.	100	5.0 -- 250

iv) **KMS501W** Magnetic Wafer Flowmeters

- For Liquid (upto 20% solids).
- K-MAGS Fully wired custom programmed, PFA (Teflon) liner, Hast-C probes, No moving parts.
- Accuracy: $\pm 0.5\%$, 85 - 253 vac or 17 - 31 vdc powered, Totalizer 8 digits. With Flowrate display.
- Process temperature: -25 to 120 °C. Measured liquid must have conductivity of at least 5 μ S/cm



Order Code	Description	Flowrange (Litres/min)		
		min. ($\pm 3\%$)	min ($\pm 0.5\%$)	max ($\pm 0.5\%$)
KMS501-015W	15 mm Wafer tube, PFA SS reinforced liner, Hast-C-probes 85-253vac	0.5	5	106
KMS501-025W	25 mm Wafer connection, " " " " " "	1.5	14	295
KMS501-040W	40 mm Wafer connection, " " " " " "	10	20	667
KMS502-050F	50mm Flanged	15	30	1100
-DC	24vdc powered version			

FEATURES



- Simple calibration setup and use.
- Suitable with most NPN & contact closure flowmeters.
- Fully isolates flowmeter pulses to PLC input.

The Universal Interface Card (UIC) provides signal scaling and an isolation interface to pulse flowmeter outputs, and re-transmits to PLC/computer inputs. Three model variants are available:

- 1) **UIC/A2** : +24VDC powered, with 24–250 vac pulse output switching via a heavy duty triac opto.
- 2) **UIC/D-24DC** : +24VDC powered, with 5-30 VDC NPN/PNP (sink/source) pulse output switching via 4N33 opto.
- 3) **UIC/D** : As above but +12VDC powered

■ x10 input. ■ Common to all is a low voltage 5-12 VDC NPN (sinking) scaled output pulse (proportional to supply voltage), which can be used for connection to counters or other devices. ■ All scaled output pulses are indicated by a LED, with pulses feeding the PLC input device having 50% duty cycle (square wave). There are two mounting holes, for fixing to panels, enclosures etc. ■ A special voltage regulator is fitted on to the card for use with a +24 VDC power supply. The UIC card supplies regulated +12VDC power to the flowmeter (where required). (Also +12VDC powered option)

CALIBRATION AND USE

■ The UIC is suitable for use with most types of pulse output flowmeters. ■ Calibrating or scaling of pulse output signals is via three decade rotary select switches (numbered 0-9) marked H (Hundreds), T (Tens) and U (Units). ■ To change calibration, use a small flat-bladed screw driver, insert into switch slot and turn arrow to desired number (**see calibration calculation examples on page 3**) ■ For batching with concrete admixtures, the MES20/25/32/40 (20 to 40mm) pulse flowmeters are primarily used.

For pulse scaling set-point values for example MES20 20mm flowmeters, refer to the following table (for a x10 input standard UIC card):

Rotary value	UIC card pulse o/p rate	Volume per pulse	Final Calibration:
H T U			
0 2 5	200 pulses/Litre	5 ml/pulse	If the liquid collected is more than pulse value shown on computer screen, then decrease the rotary decade set value by the same % difference. If the liquid collected is less than pulse value shown on computer screen, then increase the rotary decade set value by the same % difference. Note: Final calibration can also be performed via computer software scaling.
0 5 0	100 pulses/Litre	10 ml/pulse	
1 0 0	50 pulses/Litre	20 ml/pulse	
1 5 0	33.3 pulses/Litre	30 ml/pulse	
2 5 0	20 pulses/Litre	50 ml/pulse	
5 0 0	10 pulses/Litre	100 ml/pulse	

For calibration for use with larger MES meters and other flowmeters (e.g. CMM25 Magflows) see calibration calculation examples on next page..

SPECIFICATIONS

Supply voltage	+24V DC (or +5-12VDC if standard card ordered)
Voltage to flowmeter	+12 VDC regulated, supplied by UIC to power the flowmeter
Input	Accepts NPN Transistor , Open Collector or contact closure pulse inputs
Pulse input frequency max: x 10 input (standard)	2 kHz
UIC/A2 AC switching	24 - 250 vac switching* up to 1 Amp via CRYDOM AO241 solid state opto triac, with surge protection to 2500 V RMS. Drives yellow Opto22 input modules or equivalent solid state inputs. * Due to AC triac opto isolator characteristics, frequency output to computer inputs should not exceed 15Hz.
UIC/D Open Collector DC switching	5-30 VDC via 4N33 Opto, open collector (sink or source), surge protection to 7500 V RMS. (Drive White Opto22 input modules and others)
Pulse Data	Pulses from flowmeters can be needle shaped, UIC's Schmitt trigger input filters possible industrial noise. UIC output pulses are conditioned to 50% duty cycle.

UIC TERMINATION DIAGRAMS

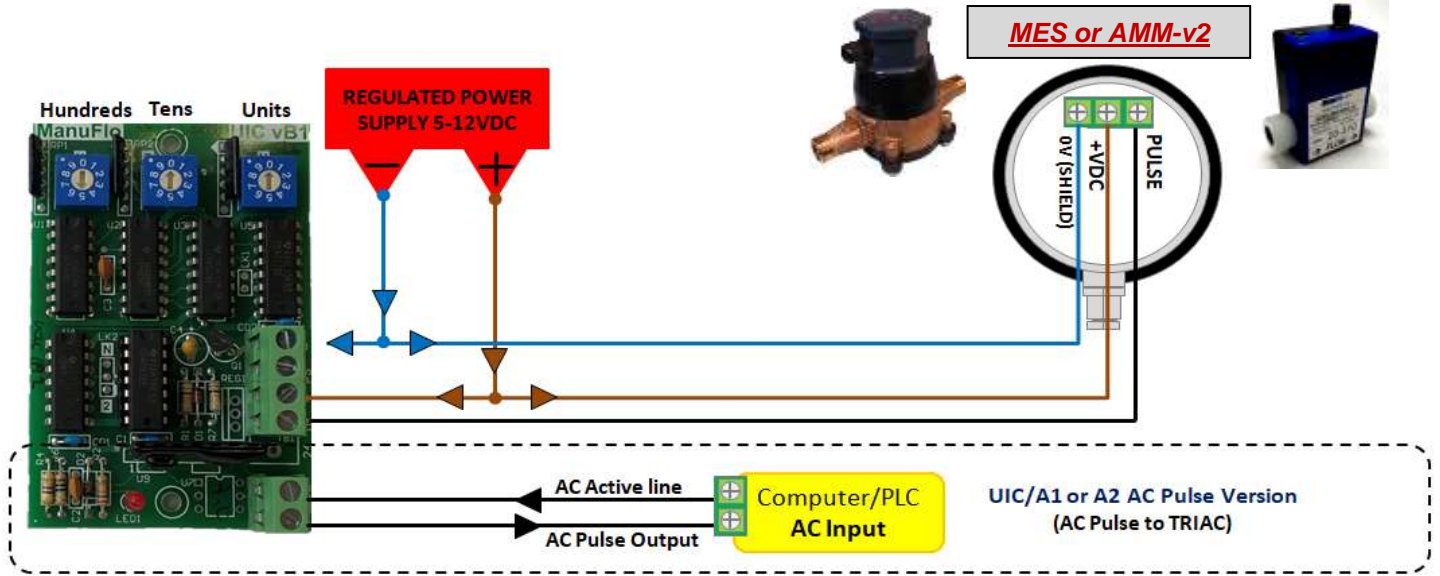

AC PULSE OUTPUT to PLC

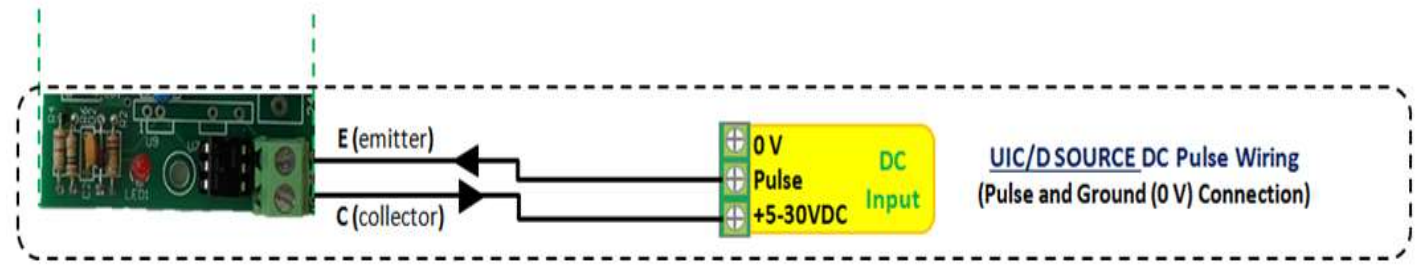
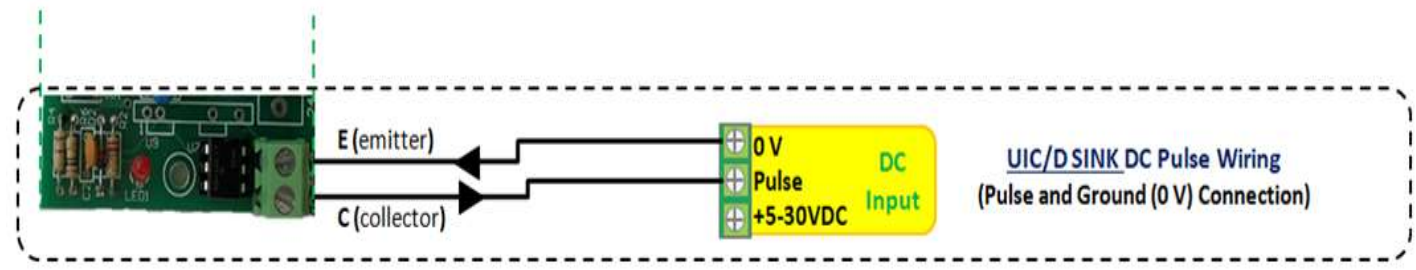

DC PULSE OUTPUT to PLC

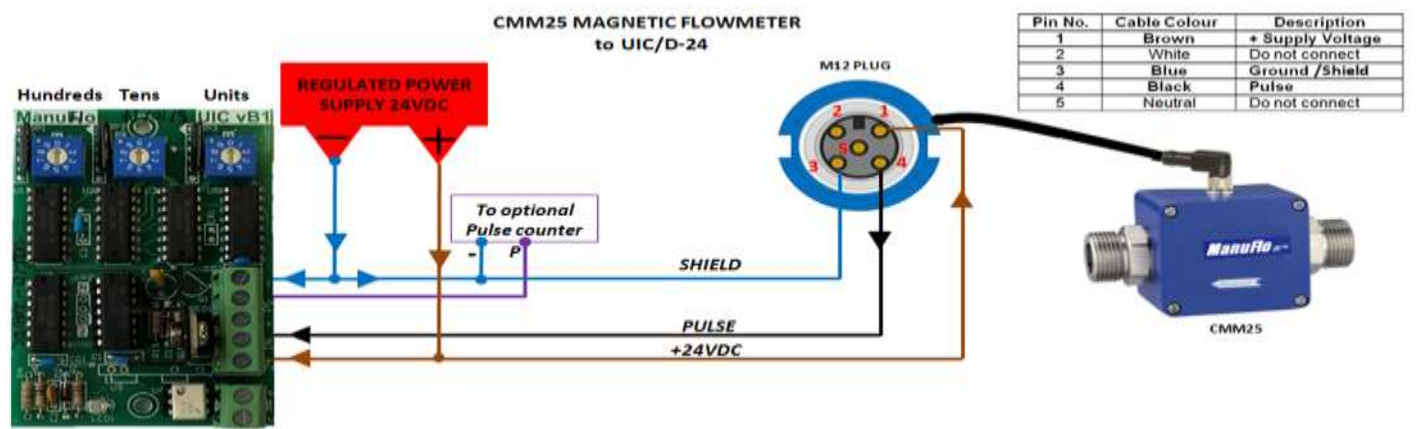

COMMISSIONING FLOWMETER / UIC INTERFACE CARD SYSTEM(s)

- Electricians must refer to the relevant system wiring diagram. Mount the UIC interface cards on a suitable panel or inside an enclosure near the computer/PLC input panel. ■ When wiring the flowmeter(s), use shielded cable. For example, when wiring 4 flowmeters in the one installation, use at least 6-core shielded cable: 4 cores for each pulse wire and at least one core for the positive DC voltage supply linked to each UIC card and the flowmeters, and one core coupled with the shield as 0.V.
- Wire the Pulse Output and return line from the dual (white) terminal to the computer/PLC pulse input(s).
- Wire the external power supply (also available from ManuFlo, to the UIC card which in turn supplies voltage to flowmeter(s). For the UICD-24 +24vdc option the Power supply must be 24V DC only, for the +12VDC versions use only +12Vdc power supply.
- Set the appropriate calibration setting on the UIC via the 3 decade rotary pots, marked H (Hundreds), T (Tens) and U (Units).
- Power up the system. ■ Prime the admix line, until liquid appears at outlet line, UIC's pulse LED is blinking and your computer screen is counting.
- **A volumetric calibration test must be performed when commissioning a new installation, and a follow-up quarterly test:** a calibrated vessel is placed near the sock, a selected batch quantity set on computer, and batched. See UIC card's brochure for calibration details. Example: MES20 flowmeter used, 10.1 Litres called on batch computer program, 100mls/pulse set on UIC (HTU=500), 10.1 litres of admixture collected in container, 101 counts on computer. 101 x100mls =10.1 Litres = CORRECT RESULT. If 10.3 Litres collected in container, is approximately 2% excess admix, so subtract 2% from the current HTU=500 setting i.e. set HTU=490. Batch again, result should BE CORRECT.

If there is no pulse output from the UIC

1. Check that the HTU settings on the UIC card are not set to H=0 T=0 U=0, and are correct for your application.
2. Make sure there is a numeric setting to match flowmeter, then Turn off power to the UIC, then turn power on again.
3. Have a low flow through flowmeter (or simulate a low flow by inputting pulses to the UIC).
4. Observe if the UIC's output LED blinks at the rate expected. Page 1 of 5
5. If the problem still exists, repeat steps 1 to 4 (2-3 times) until the UIC card autocorrects itself.
6. If the UIC does not autocorrect, then return the suspect UIC card to ManuFlo for further checking or repair.

CALIBRATION VALUES using AMM15, 20 and 25mm Magflows		
UIC card with STANDARD x10 pulse input multiplier		
Pipe size (mm)	UIC Set Value H T U	Output pulses per Litre to PLC/computer
AMM15 AMM20 1000 ppl	5 0 0	100 mls. per 1 pulse
	2 5 0	50 mls. per 1 pulse
	1 2 5	25 mls. per 1 pulse
	1 0 0	20 mls. per 1 pulse
	0 5 0	10 mls. per 1 pulse
	0 2 5	5 mls. per 1 pulse
0 1 0	2 mls. per 1 pulse	
AMM25 500 ppl	5 0 0	200 mls. per pulse
	2 5 0	100 mls. per pulse
	1 2 5	50 mls. per pulse
	0 5 0	20 mls. per pulse
	0 5 0	10 mls. per pulse

CALIBRATION VALUES using MAGFLOWS (e.g. KMS, MFS, RMS)		
UIC card with STANDARD x10 pulse input multiplier		
Output pulse from Magflow	UIC Set Value H T U	Output pulses per Litre to PLC/computer
1 pulse / 1 Litre	0 1 0	1 pulse per 2 Litres
	0 2 5	1 pulse per 5 Litres
10 pulses / 1 litre	0 5 0	1 pulse per 1 litre
100 pulses / 1 Litre	0 1 0	20 mls. per pulse
	0 2 5	50 mls. per pulse
	0 5 0	100 mls. per pulse

$HTU = \frac{\text{input pulses/Litre}}{\text{output pulses/Litre}} \times 5$	<p>e.g. to convert 20 pulses/Litre to 1 pulse/Litre:</p> $HTU = \frac{20 \text{ pulses/Litre}}{1 \text{ pulse/Litre}} \times 5$ $HTU = 100 \text{ (i.e. H=1 T=0 U=0)}$ <p>Calculation Example</p>
---	---

CALIBRATION VALUES using MES flowmeters

Meter Model	Size	UIC/A card setting	Pulse Output Value	Flowrate	Equivalent
		H T U			Pulse Frequency
MES20	20mm	5 0 0	100 mls per pulse	1.2 Litres/sec	12 Hz**
"	"	2 5 0	50 mls per pulse	0.65 Litres/sec	13 Hz
"	"	1 0 0	20 mls per pulse	0.26 Litres/sec	13 Hz
"	"	0 5 0	10 mls per pulse	0.13 Litres/sec	13 Hz
(Maximum flowrate of MES20 is about 1000mls/sec i.e. 1Litre/sec, 60 LPM)					
MES25	25mm	2 7 7	100 mls per pulse	1.3 Litres/sec	13 Hz
"	"	5 5 5	200 mls per pulse	1.8 Litres/sec	09 Hz**
"	"	6 9 3	250 mls per pulse	1.8 Litres/sec	7.2 Hz
(Maximum flowrate of MES25 is about 1830mls/sec i.e. 1.83 Litres/sec, 110 LPM)					
MES32	32mm	1 3 0	100 mls per pulse	1.3 Litres/sec	13 Hz
"	"	2 6 1	200 mls per pulse	2.6 Litres/sec	13 Hz**
"	"	3 2 6	250 mls per pulse	3.0 Litres/sec	13 Hz**
"	"	6 5 2	500 mls per pulse	3.0 Litres/sec	06 Hz
(Maximum flowrate of MES32 is about 3000mls/sec i.e. 3 Litres/sec, 180 LPM)					
MES40	40mm	1 4 5	250 mls per pulse	3.2 Litres/sec	13 Hz**
"	"	2 9 0	500 mls per pulse	5.0 Litres/sec	10 Hz**
"	"	5 8 0	1 Litre per pulse	10.0 Litres/sec	10 Hz
(Maximum flowrate of MES40 is about 6000mls/sec i.e. 6 Litres/sec, 300 LPM)					

Interface Cards – UIC for Admixtures

Usually used
with
Bottle Systems
Mainly in Asia.

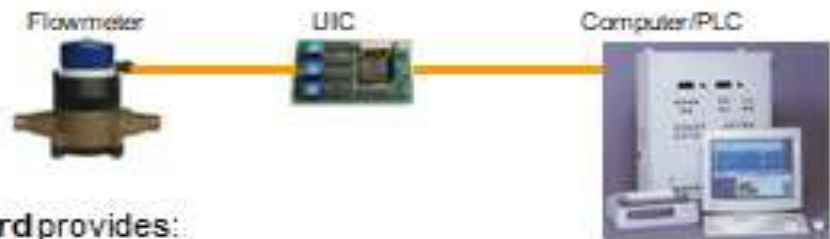

The UIC **Universal Interface Card** provides:

- signal **scaling** and
- an **isolation interface**

to pulse flowmeter outputs, and re-transmits to PLC/computer inputs. Models available:

- 1) **UIC/A1** : 110-240 vac pulse switching via a triac opto
- 2) **UIC/A2** : 24-250 vac pulse switching via a **heavy duty** triac opto
- 3) **UIC/D** : 5- 30 VDC NPN/PNP (sink/source) pulse switching via a 4N33 opto
- 4) **-24DC** : for 24VDC powered option

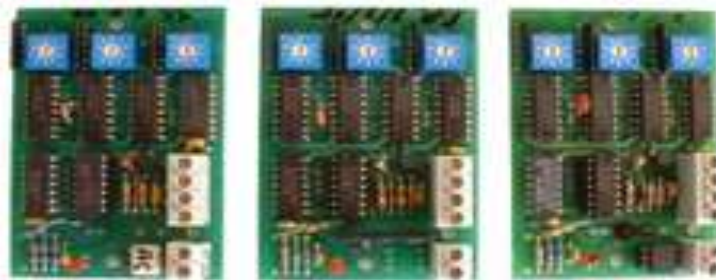

Interface Card - UIC – installation

- Mount UIC interface cards on a suitable panel or inside an enclosure near the Computer/PLC input panel.
- When wiring the flowmeter, use **shielded cable**.
For example, when wiring 4 flowmeters in the one installation, use at least 6-core shielded cable: 4 cores for each pulse wire and at least one core for the positive DC voltage supply linked to each UIC card and the flowmeters, and one core coupled with the shield as O.V.
- Wire the **Pulse Output and return line** from the dual (white) terminal to the computer/PLC pulse input(s).
- Wire the **external power supply** (also available from ManuFlo), to the UIC card which in turn supplies voltage to flowmeter(s).
Power supply must be +5 to 12 VDC only, noting each UIC card/flowmeter can draw up to 25mA each.
- Select the appropriate **calibration pulse ratio** setting via the 3 decade rotary pots, marked **Hundreds(H) Tens(T) and Units(U)**.
- **Power up the system.**
- **Prime the admix line**, until liquid appears at outlet line, UIC card's pulse LED is blinking and the computer screen is counting.
- A **volumetric calibration test** must be performed when commissioning a new installation, and a follow-up quarterly test: a calibrated vessel is placed near the sock, a selected batch quantity set on computer, and batched.



Interface Card - UIC - scaling

Calibrating or scaling of pulse output signals is via 3 rotary select switches (numbered 0-9) marked **Hundreds (H)**, **Tens (T)** and **Units (U)**.

Use small flat-bladed screwdriver, insert into switch slot and turn arrow to desired number.

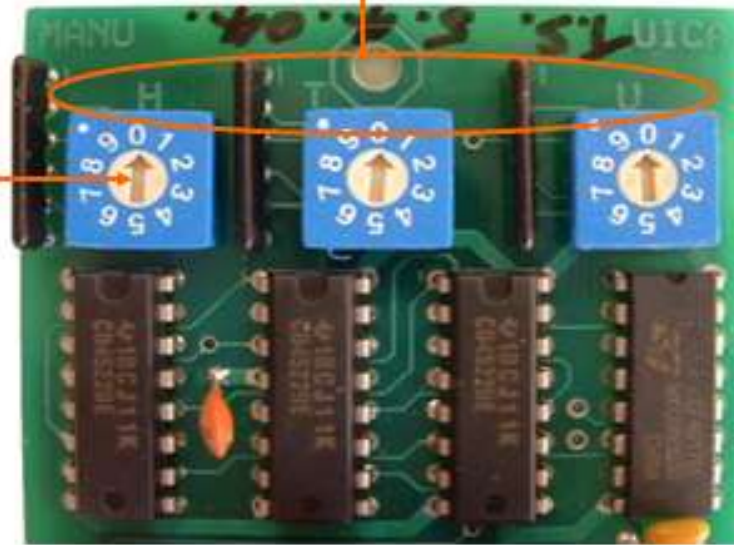

$$HTU = \frac{(\text{input ppL}) \times 5}{(\text{output ppL})}$$

e.g. to convert 1000 ppL to 10 ppL:

$$\begin{aligned} HTU &= \frac{1000 \text{ ppL} \times 5}{10 \text{ ppL}} \\ &= 100 \times 5 \\ &= 500 \\ &= (H=5) (T=0) (U=0) \end{aligned}$$



6

(c) Manu Electronics 2006

Interface Card - UIC - scaling



For batching with concrete admixtures, the MES20/MES20S 20mm pulse flowmeters are primarily used. Scaling values (x10 input card standard):

Final Calibration:

- If the liquid collected is **more** than pulse value shown on computer screen, then **decrease** the rotary decade set value by the same % difference.
- If the liquid collected is **less** than pulse value shown on computer screen, then **increase** the rotary decade set value by the same % difference.
- Note: Final calibration can also be performed via computer software scaling.

Rotary decade value H T U	Pulse output rate
0 2 5	5 mls/pulse
0 5 0	10 mls/pulse
1 0 0	20 mls/pulse
1 5 0	30 mls/pulse
2 5 0	50 mls/pulse
5 0 0	100 mls/pulse
9 9 9	200 mls/pulse



7

(c) Manu Electronics 2006

Interface Cards - UIC - Calibration

Volumetric Calibration example:

- MES20 flowmeter used.
- **10.1** Litres called on batch computer program.
- 100 mls/pulse set on UIC (HTU=500)
- **10.1** Litres of admixture collected in container.
- 101 counts on computer.



101x100mls/count=10.1 litres = **CORRECT RESULT.**



Interface Cards - UIC - Calibration

Volumetric Calibration Example:

- MES20 flowmeter used.
- **10.1** Litres called on batch computer program.
- 100 mls/pulse set on UIC (HTU=500)
- **10.3** Litres of admixture collected in container.
- 101 counts on computer.

INCORRECT RESULT. This is

$$\frac{10.3}{10.1} = 102\% \text{ or } 2\% \text{ excess admix, so}$$



- subtract 2% from the current HTU=500 setting i.e. set HTU= 500-10 = 490.
- Batch again, result should BE CORRECT.

Interface Cards - UIC – Pulse Trouble Shoot

• If there is no pulse output or it is erratic from the UIC

1. Check that the HTU settings on the UIC card are not set to H=0 T=0 U=0, and are correct for your application.
2. Turn off power to the UIC, NOW SET a VALUE e.g. HTU=100, then turn the power on again.
3. Run some fluid through the flowmeter (or simulate flow by inputting pulses to the UIC card).
4. Observe if the UIC's output LED blinks at the rate expected for the divided output pulse rate.
5. If the problem still exists, repeat steps 1 to 4 (2-3 times) until the UIC card autocorrects itself.
6. If the UIC does not autocorrect, then return the suspect UIC card to ManuFlo for further checking or repair.



Full support at:

http://www.manuelectronics.com.au/pdfs/Training_Manual_ManuFlo%20-2020.pdf

ManuFlo®™

Flow Measurement & Control Products

Rev: 0720ATM

MANUFLO

Ph: +61 2 9938-1425, 9905-4324

Web : www.manuelectronics.com.au

Email: sales@manuelectronics.com.au