

110VAC Powered Model with 110VAC I/O

FEATURES

- Up to 4 Dual-Channel Modules (DCMs) can be mounted on Motherboard, for the creation of a 2, 4, 6, or 8 channel unit.
- All parameters and entries are fully programmable via a plug-in hand held keypad.
- Pulse Comparator for Dual Flowmeter system.
- **New feature in V1.8 software: can de-select the comparator function, so that each channel shows the reading from one flowmeter only.** 
- Dual Display Counters for each channel (for Comparator function).
- Input Pulse scalable for use with most types of Flowmeters.
- All display readouts in Litres to 3 decimal places, with instantaneous flowrate display reading.
- Accumulated batch totals (grand totals) for inventory records.
- Initial Start and Pulsefail Safety.
- Low and High Flow range settings. Pulsefail Safety safeguards against exceeding flowmeter operating ranges.
- Maximum pulse output frequency alarm, for PLC input safety.
- Maximum Batch Limit Safety.
- Output Pulse Division to PLC/Computer scalable.
- 24-240 vac or 5-25 VDC pulse switching.
- Input/Output control with optional voltages. ,
- Manual Batch facility, with Disable option.
- Master Audible alarm function, Alarm condition for leaky check valves (back flow).
- Can be used for water channels.



ME2008-8-1B-2B-3B

Simultaneous batching of all 8-channels without any sequencing requirements of starts.

INTRODUCTION

The ME2008 is a microprocessor-based batch safety interface card for management of flowmetering admixture liquids in the concrete production industries. It's design is at the request and requirement of suppliers/producers/users of construction chemical products. The software incorporates safety features designed to cover, detect and warn for most flowmetering conditions during/after the batch cycle, making the flowmetering system one of the safest in the world. The ME2008 can be used with a wide range of signal output flowmeters in conjunction with a range of PLC/Computer auto batch systems. All message status functions are displayed at all times, and the settings are easily retrieved and displayed. This helps make the ME2008 very user-friendly. The unit consists of:

- 1x **MOTHERBOARD** (with power supply) complete with 8 individual pushbuttons for manual batch facility, along with a pushbutton to select (or scroll) menu functions, a button for manual reset of batch displays and a button for alarm muting (can be disabled), all enclosed in a wall/panel mount ABS enclosure.
- 1,2,3 or 4x **DUAL CHANNEL MODULE (DCM) plugable PCBs** with dual-line LCD displays with backlight.
- 1x Hand held **plug-in programmer** for entering parameters.

The ME2008 is an expanded version of the ManuFlo 6-channel ME2000 safety interface card, with a Motherboard expanded to have 8-channel capability. Dual Channel Modules for the ME2000 and ME2008 are interchangeable.

OPERATION

Flowmeters of various sizes can be connected to the inputs. ME2008 accepts 8 external start commands. It delivers conditioned AC voltage (24-240vac) or DC low voltage (sink or source 5-24 VDC) pulses to a PLC/computer with optical isolation. The ME2008 controls and manages up to 8 admixture products / 8 flowmeters (or up to 16 flow meters, 2 per channel, if you utilize the comparator function).

ME2008 can be used as a manual pushbutton batch controller unit. This function can be disabled via a link for computer control only start operations. The handheld plug-in programmer is unplugged after all parameters have been setup.

When the PLC/Computer system starts, the ME2008 begins counting in millilitres, and the output pulses are re-transmitted to the PLC/Computer input at the divided pulse value. A sophisticated safety management watches for any malfunction in the system, flowmeter or batch computer during the batch cycle. If a fault is detected, the ME2008 will override and shutdown the faulty channel, and give alarm warnings. The computer provides auto reset at completion of batch, resetting all counters. All activity is logged on grand totalisers for inventory management data. Also included is an instantaneous flowrate reading per channel, which indicates if the operating range of each flowmeter is exceeded.

INSTALLATION

Find an appropriate position to mount the ME2008 housing box, preferably within visual distance to operator. Using flexible wires, wire the ME2008 according to the diagrams:

- Figure 1. Overall wiring schematic. Page 3.
- Figure 2. Motherboard Wiring Diagram, on page 4.
- Figure 2. Dual Channel Module (DCM), on page 4.
- Figure 4. Dual Channel Module (DCM) wiring, on page 5.

The normal order of connections is:

1. To reduce industrial noise, connect the computer's 110 vac supply (L is active load, N is neutral, E is earth) to the Motherboard **plug X5** (see Figure 2, page 4. **X5** is a 4-pin green-coloured plug).
2. Connect the Master Reset from the computer to the top pin only (marked RST) of the Motherboard **X1 plug** (3-pin green coloured).
3. Using shielded cable, connect flowmeters (with no earthing on the bodies of the flowmeters) to the ME2008's Dual Channel Modules (DCMs), to 6-pin green **plug X4**, as shown in Figure 2 (page 3) and (page 5) . Use minimum 2-core shielded cable per flowmeter to the DCM's **X4 plug**. If using one flowmeter per channel, use Pulse 1A and Pulse 2A, and +12 VDC and S (Shield) = 0V which are both common for flowmeters.
With software v1.8 or above, set the "Diff. channels" value to '1' (i.e. disable comparator function), then just wire to PULSE 1A and 2A for each respective flowmeter.
4. (a) For first channel:
 - connect the **110 vac START** signal from PLC/Computer to the DCM **X2 plug** (6-pin, black colour), pin S1.
 - connect the **110 vac active** side of **contactor coil** to DCM **X2 plug**, pin R1.
 - Connect Neutral side of contactor to main power supply of the ME2008.
 (b) Similarly connect for the second channel, using DCM **X2 plug** pins S2 and R2.
 (c) For the 110vac **PULSE OUTPUTS** connect to pin **O1** for channel 1 and pin **O2** for channel 2 of the **X2 plug**
 (c) **If using the low voltage DC (5 - 24 VDC) pulse output to the PLC/Computer, connect the DCM X3 plug 4-pin white plug, C = Collector, E = Emitter) to the PLC/Computer.**
6. **To disable the front manual batch pushbuttons**, remove link LK1 located on motherboard near the Alarm buzzer (see Figure 2 on page 4). This will avoid misuse of manual starts. The other manual functions "select", "mute" and "Reset" will be still fully functional. Plug-in LK1 to re-activate manual batch functions.
7. The entry or reconfiguration of program parameter data is achieved with a 4-button keypad programmer (see Figure 1 below) that is plugged into the appropriate socket in the external CAT5E Data Entry port on the outside of the ME2008 (see photo on bottom right of page 8). The programmer plug is keyed so that it can only be plugged in the correct way.



Each Dual Channel Module (DCM) is programmed one at a time. Plug the Programmer into the DCM to be programmed (the programming plug location is shown in Figure 2 on page 4).

If equipped with external programming panel (8CAT5E for 8 channel), connect the programmer CAT5E plug to the external panel with marked channels 1 to 8 (2 channels per terminal).

To start programming, push either arrow button (→ ←) on the Programmer. Cursor (digit) will flash on the DCM display. Push UP or DOWN to change numeric values. Push arrows to scroll through the individual numeric settings. Once programming is completed, push either arrow button (→ ←) until no digits are blinking, data is now entered into memory. Unplug the Programmer, then plug it in to the next module and repeat data entry to programme another module.

See **OPERATING INSTRUCTIONS** on page Error! Bookmark not defined., for program menu display and description. **Note: For guide to entering complete data safety features for each flowmeter type, see Flowmeters Data Guide on page 10.**

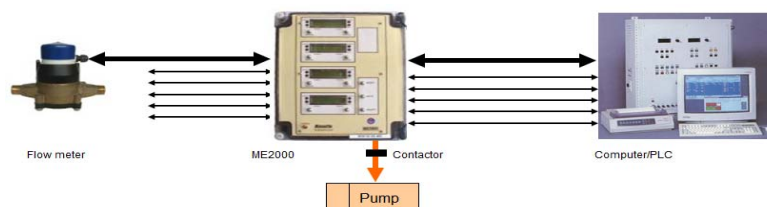

ME2008-1B-2B-3B

START/RUN/RESET WIRING DIAGRAM

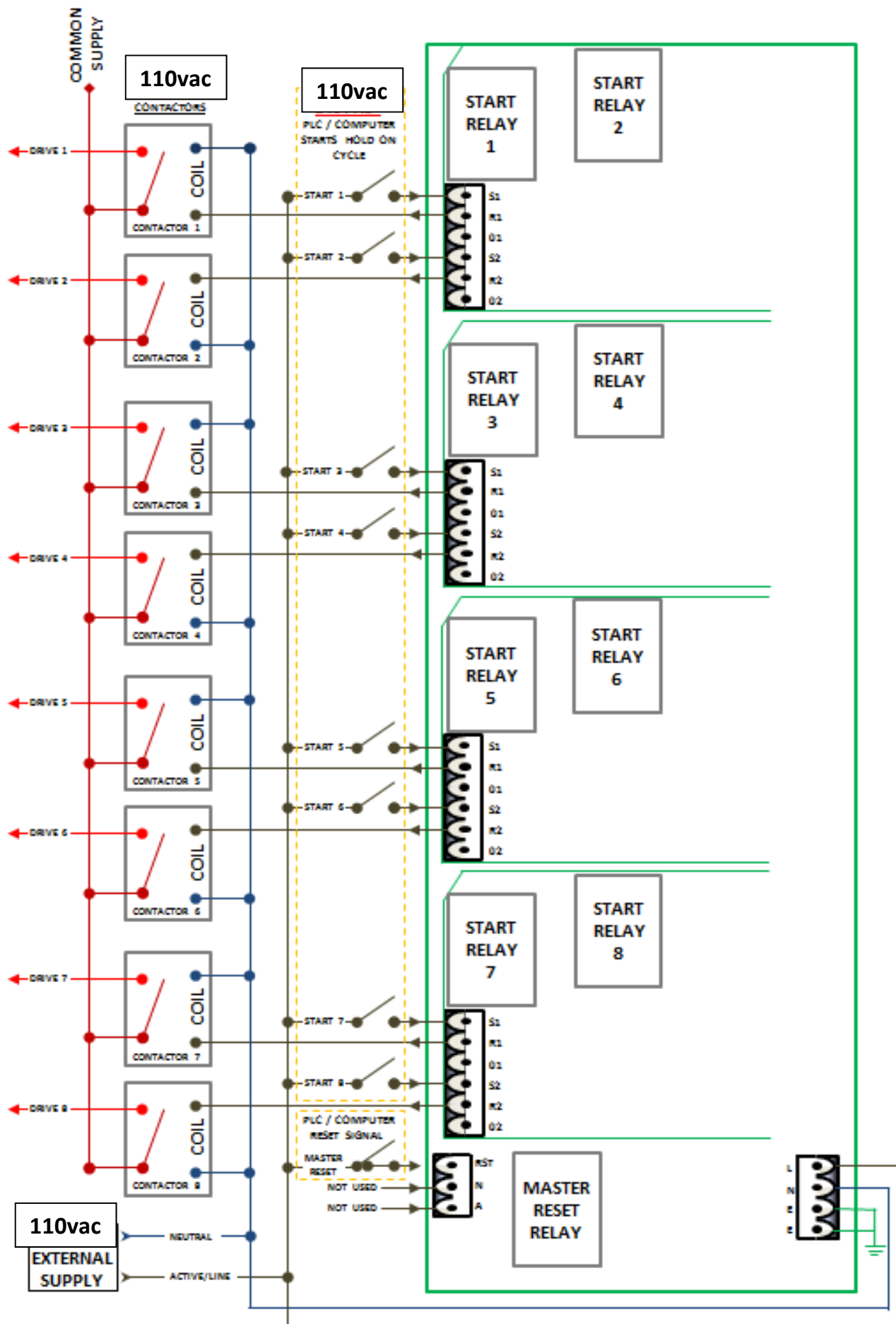



Figure 1. Motherboard Wiring Diagram, X1 and X5 plugs

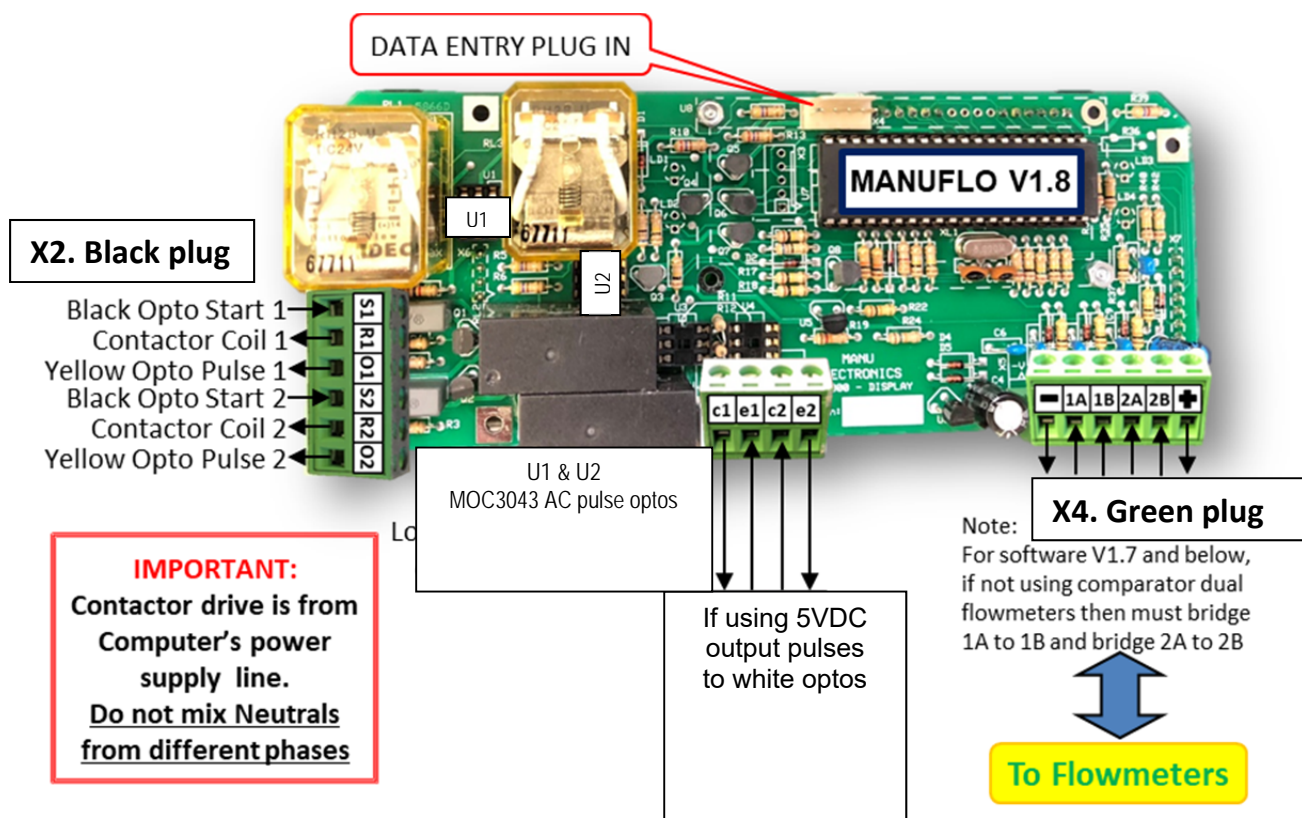
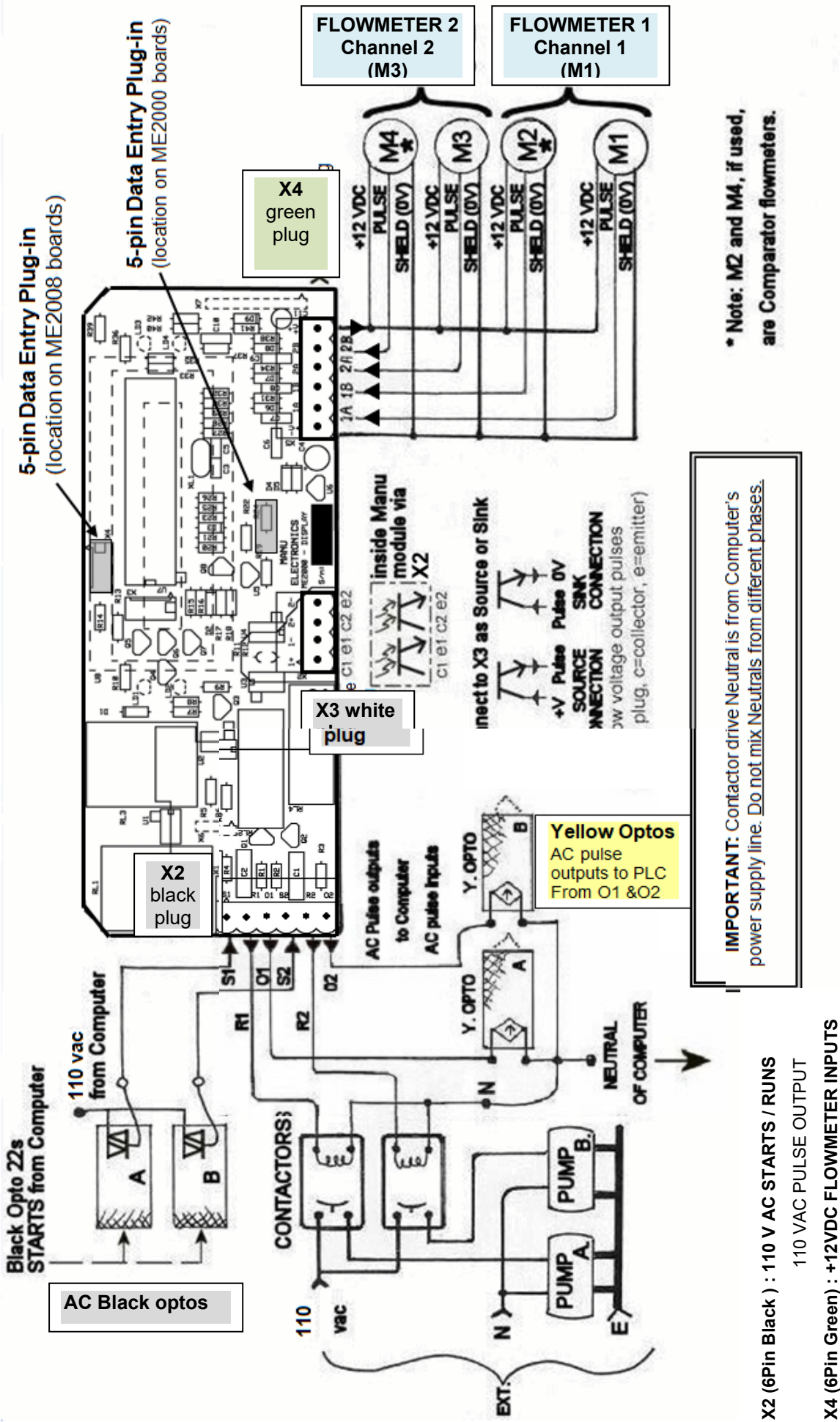

Figure 2. Dual Channel Module (DCM)

Note: Dual Channel Modules for the ME2008 and ME2000 have slightly different component layouts (the most obvious is the connection to the external CAT5E Data Entry port) but the boards are functionally equivalent and are interchangeable.



110 VAC option shown

Figure 4. Dual Channel Module (DCM) wiring

wired with PLC I/Os, flowmeters, pumps.

OPERATING INSTRUCTIONS

* Switch on power to the ME2008 interface safety unit. * Scroll through the settings by pressing SELECT. Refer to the Display Diagram below for procedures and settings of required parameters. * See "Flowmeter Data Guide" on page 10 for recommended data for each flowmeter type/size characteristics/flowrates.

ME2008 Display Menu

⇒ Power On:

**MANU
ELECTRONICS
ME2000 V1.8**



⇒ 1. Push Select:

**000.000 000.000
000.000 000.000**

Batching function display in "LITRES" to 3 decimal places. At any time you can skip functions and return to normal by pushing RESET (You cannot reset while pumping is in progress).

⇒ 2. Push Select:

**Flow (l/s)
000.000 000.000**

Flow Rate Function in Litres/second (to 3 decimal places).

⇒ 3. Push Select:

**Total (l)
000000 000000**

Grand Total accumulation.
To reset: push 2 buttons at once on 4-button programmer.

⇒ 4. Push Select:

**Input (p/l)
1000.00 1000.00**

K-factor / Calibration:
sets pulse input value per litre, according to flowmeter used e.g. MES20 1000pulses/litre, MES25 0555pulses/litre.

⇒ 5. Push Select:

**Output (l/p)
00.010 00.010**

Pulse Output Volume Value (Litres /pulse).
Sets division of output pulses to suit computer/PLC.
Resolution from 1ml. Example shows 10ml.
See also "Program Record Sheet" (page 11).

⇒ 6. Push Select:

**Min. Flow (l/s)
00.010 00.010**

Minimum flowrate
(set this according to flowmeters' recommended minimum). Pump will be stopped if the flowrate falls below this value.
Previously known as **Pulsefail** in ME697, ME995/188 units.

7. Push Select:

Max. Flow (l/s)	
01.000	01.000

Maximum flowrate
(set this according to flowmeters' recommended maximum). Pump will be stopped if the flowrate exceeds this value.

⇒ 8. Push Select:

Dose Limit (l)	
010.000	010.000

Sets maximum acceptable limit per batch (overrides computer selection). If limit is reached, pump is stopped and "Overdose" warning will be displayed.

⇒ 9. Push Select:

Max Backflow (l)	
000.100	000.100

The **Backflow** function raises an alert if the check (non-return) valves leak. Set to the desired maximum allowance of backflow.

⇒ 10. Push Select:

Difference (%)	
05.0	05.0

COMPARATOR (5% = $\pm 2.5\%$)
This function is used to compare 2 flowmeters in series. If the flowmeters differ by more than the allowed percentage, the pump will be stopped and an alarm triggered. From software Version 1.5 onwards, the comparator function only operates during batching.

⇒ 11. Push Select:

Start Delay (s)	
02.0	02.0

Start Delay is the time (in seconds) allowed for pump to start before the Pulse Fail safeties activate. After the Start Delay period, the safeties will shut down the pump drive if no flowmeter pulses are received.

⇒ 12. Push Select:

Stop Delay (s)	
02.0	02.0

Stop Delay is the time (in seconds) allowed for the pump to settle after stopping, before back flow detection commences.

⇒ 13. Push Select: **(Only available from software Version 1.8)**

Diff. channels	
1	1

Difference Channels : enables/disables the comparator function, for each channel of the two-channel module.
When value is "1", the comparator is disabled, and the display for that channel shows the reading from one flowmeter.
When value is set to "2", the comparator is enabled, and the display for that channel shows the readings of two flowmeters in series.

⇒ 14. Push Select:

Max Out Rate(Hz) 0015
--

Max Out Rate is the maximum allowed rate of output pulses to the computer. If the maximum is exceeded, then the pump stops, then the ME2000 memory sends extra pulses to the PLC/Computer's AC Yellow Optos (under the 15 Hz max. input rate) or low scanrate systems.

NOTE:

(1) DO NOT SET THE MAX OUT RATE UNNECESSARILY HIGH, as this will affect the duty cycle of the pulses (i.e. will narrow the pulse width) which may make it difficult for the receiving PLC to detect the pulses.

Example: if the receiving PLC can only detect pulses at a rate up to 15 Hz, then set MAX OUT RATE to 15 and not to 100.

(2) Extra pulses received (above the allowed rate) represent actual extra volume measured by the flowmeter and ME2000, but which would have otherwise not been fully counted by the PLC/Computer system. (This situation is different to actual "inflight overflow", where a DEDUCT value must be programmed in the computer system to stop the pump earlier).

IMPORTANT: PLC/Computers that accept AC input pulses have a pulse input frequency limit of 15 Hz, so for the ME2000 to protect such systems and prevent overdose, set values in the ME2000:

*** MAX OUT RATE to 15Hz or less; and**

*** OUTPUT (LITRES/PULSE) to a value so that, at your maximum operating flowrate, pulses to the PLC/Computer will not exceed 15Hz.**

e.g. if your maximum operating flowrate is 40 Litres/minute, and you set OUTPUT (LITRES/PULSE) = 0.050 (i.e. 50 mls/pulse), the ME2000 will output 13.4 pulses/second (i.e. < 15Hz) to the PLC/Computer when flow is 40 Litres/minute.

NOTE: For White Opto DC inputs set to 0040 40Hz.

⇒ 15. Push Select:

MANU ELECTRONICS ME2000 V1.8

Returns to intro display.

⇒ 16. Push Reset:

000.000 000.000 000.000 000.000
--

Returns to the Batch function.

Display is in "LITRES" to 3 decimal places.

WARNING

Only after all products are batched, should totals be reset (does not affect accumulated totals).

All ME2000/2008 should be upgraded with the latest v1.8 software. Micro chips can be purchased & plugged-in.

Before you leave the plant, you must take a VOLUMETRIC calibration of quantity dispensed and cross-reference with ME2008 readings !!!

ALARM SAFETY STATUS

If any of the safety features are triggered, the relevant alarm will come on. The Display will indicate status of the channel that is in alarm condition (see message explanations on page 11). In this case, as a precaution the ME2000 will shut down pump drive of the faulty channel only, allowing for further examination of the problem.

SAFETY PROCEDURE IN EXAMINING THE PROBLEM

If the alarm comes on, **DO NOT** push RESET immediately - just push MUTE to silence alarm, then observe display and take note of batch readings and alarm message. Address the problem if possible.

WAIT for other channels to complete batch, then push RESET to be ready for the next batch.

✓ See **Troubleshooting Guide** on pages 12 – 13.

ME2008 - SPECIFICATIONS

Display	One 2x16 character dot matrix backlit display per Dual Channel Module (DCM).
Motherboard	Accepts up to 4 plug-in Dual Channel Modules.
Power Supply	110 vac (See options guide for other voltages), via Motherboard X5 green plug .
Current Draw	1.5 Amps max. (≥ 2.5amps Power Supply Recommended)
Supply to Flowmeters	12 VDC (10mA per flowmeter), via X4 green plug .
Pulse Inputs	NPN sink pulse or Reed Switch pulses, 2 flowmeters per module (4 for comparator). Input calibration to 3 decimal places. Most types of flowmeters can be connected and calibrated.
Input count speed	2 kHz maximum.
Output pulses to computer	110VAC (24-240) vac triac switching via MOC3043 (2000V surge protection) DCM X2 black plug . or 5-25 VDC sink/source pulse via 4N33 open collector opto (DCM X3 white plug). (7500V rms surge protection). All pulses are divided via "Output Pulse Value" calibrator.
Computer starts/reset	110vac , start DCM X2 black plug , Motherboard master reset X1 green plug).
Output starts	110vac, start and hold (DCM X2 black plug).
Manual Batch Commands	Starts: 8 momentary-hold push buttons for each channel (when link enabled). Master Reset: 1 pushbutton. MUTE: 1 pushbutton. SELECT: 1 pushbutton.
LED functions	"Output" (divided pulses) indicated via flashing LEDs "Run" (manual starts) indicated via illuminated LEDs.
Power ON/OFF	Via "Power" switch.
Wiring/Connection	Connected to five mated plugs, allows unplugging of PCBs for easy replacement.
Fuse	2 Amp. Fuse holder on motherboard.
Enclosure & Dimensions	IP58 ABS lid/box. Size: 310mm L x 245mm W x 140mm D.
Weight (with 3 modules)	2.6 kg

Display Functions

Operation	Via plug-in 4-button hand-held programmer.	
Volume displayed	In Litres, to 3 decimal places (smallest increment is 1 millilitre).	
Flowrate display	In Litres per Minute, to 3 decimal places.	
Grand Total	In total Litres.	
Input calibration	Pulses per Litre, to 9999.99	(Default: 1000.00 = MES20)
Output pulse value	From 1ml to 99.999 Litres per pulse	(Default: 00.010 = 10mls)
Min flowrate safety	Min. from 1 mls to 99.999 Litres per second	(Default: 00.010, 10 mls for MES20)
Max flowrate safety	Max. 99.999 Litres per second	(Default: 01.000, 1 Litre for MES20)
Dose Limit	Max. 999.999 Litres per batch cycle	(Default: 010.000)
Max Backflow	From 1mls to 999.999 Litres	(Default: 000.100)
Comparator difference	0.1 to 99.9%	(Default: 5.0% i.e. +/-2.5%)
Start Delay	0.1 to 99.9 seconds	(Default: 2.0)
Stop Delay	0.1 to 99.9 seconds	(Default: 2.0)
Max Output pulse rate	0001 to 9999 Hz	(Default: 12)
Pulse fail	Is the function of Min/Max flowrate safety functions.	

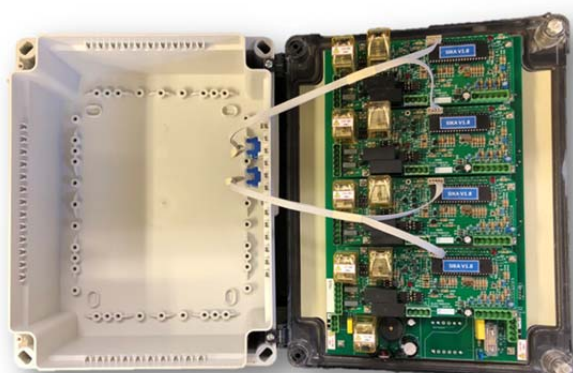

ME2008 8-channel unit,
opened,
with HP plug-in Programmer.



ME2008 8-channel unit,
with 8CAT5E external panel and
HP-CAT5E plug-in Programmer.

FLOWMETER DATA GUIDE FOR ME2008 DATA ENTRY

ME2008 setup data for various flowmeters:

Set to 30-50%
of the usual
flowrate of
the installation.Set to 90% of the
specified maximum
flowrate of the
flowmeter.**Manu Flowmeters**

Model No	Description	Input pulses/Litre	Min. Flow Litres/sec	Max. Flow Litres/sec
MES20	20 mm pulse flowmeter	1000.00	00.100	01.000
MES25	25 mm pulse flowmeter	0552.00	00.150	01.800
MES32	32 mm pulse flowmeter	0261.00	00.200	03.000
MES40	40 mm pulse flowmeter	0116.00	00.300	05.600
MES20R	20mm reed pulse flowmeter	0061.00	00.100	01.000
MEA15	15 mm pulse flowmeter	1000.00	00.020	00.600

Other Manufacturer Flowmeters

Model No	Description	Input pulses/Litre	Max. Flow Litres/sec
M25 RCDL	5/8" pulse flowmeter	0275.19	01.562
M35 RCDL	3/4" pulse flowmeter	0175.70	02.180
M40 RCDL	1" pulse flowmeter	0124.56	02.500
M70 RCDL	1" pulse flowmeter	0064.91	04.300

Many other types of flowmeters can be used with the ME2008.

Program parameters can be factory-entered or done onsite via the plug-in programmer (see page 8).

Order Codes for ME2008

ME2008-6 6 channel unit (3 module) } then must also choose one option from
ME2008-8 8 channel unit (4 modules) } at least EACH of the following three groups:

(1) Power Supply	-1A	240 vac power supply
	-1B	110 vac power supply
	-1C	24 vac power supply
	-1D	24 VDC power supply
(2) Start Input/Output Drives & Master Reset (from PLC starts)	-2A	240 vac start/reset relay logic fitted.
	-2B	110 vac start/reset relay logic fitted.
	-2C	24 vac start/reset relay logic fitted.
	-2D	24 VDC start/reset relay logic fitted.
	-2E	12 VDC start/reset relay logic fitted. Negative switching.
(3) Pulse Output (to PLC input pulses)	-3A	240 vac Moc3041 triac pulse output switching (only with '-1A' 240vac power supply option)
	-3B	Same ac voltage as for the start/reset option (i.e. 24vac or 110vac)
	-3C	5-30 VDC Open Collector pulse output. Suits Jonel/Compbatch/Autocon computers.
Other Options	-V1.8	Software version with option to disable comparator function (each channel has 1 counter per flowmeter instead of 2)
	-IR	Independent Resets for each 2-channel module in the ME2008.
	-USA	USA units (non-metric) e.g. Gallons.
	8CAT5E	4-way external panel, for programming up to 4 dual modules (includes HP-CAT5E)
Spares	HP-CAT5E	Programmer with CAT5E plug.
	HP	Spare hand-held plug-in keypad programming module.
	HK	Hinge Kit.

Examples of ME2008 order codes for common computer configurations (always check the configuration for your computer):

Model	Size	Pulse Output value	Max Safe Flowrate not to exceed computers Current AC digital input count limit speed of 14Hz (set in Max. Out Rate) ↓		
			litres/sec	litres/min	Hz
MES20	20mm	10 mls per pulse	0.14 litres/sec	8.4 litres/min.	14hz
"	"	20 mls per pulse	0.28 litres/sec	16.8 litres/min.	14hz
"	"	25 mls per pulse	0.35 litres/sec	21.0 litres/min.	14hz
"	"	30 mls per pulse	0.42 litres/sec	25.2 litres/min.	14hz
"	"	50 mls per pulse	0.70 litres/sec	42.0 litres/min.	14hz
"	"	100 mls per pulse	1.40 litres/sec	84.0 litres/min	14hz
MES25	25mm	100 mls per pulse	1.40 litres/sec	84.0 litres/min.	14hz
MES32	32mm	150 mls per pulse	2.10 litres/sec	126.0 litres/min.	14hz
MES40	40mm	200 mls per pulse	2.80 litres/sec	168.0 litres/min.	14hz

ME2008 - Program Record Sheet

Serial Number : _____ Date : _____
 ME2008 Part No. Config : _____ Software Version : _____
 Voltages : _____

Display in: Litres Gallons

		Channel							
		1	2	3	4	5	6	7	8
Flowmeter Model (part no.)									
K-FACTOR (CALIBRATION) If not known: Set input parameter to 1, then run liquid, divide volume by count = pulses per unit.									
Input Pulses	• per Litre								
	• per Gallon								
PULSE OUTPUT VOLUME VALUE TO PLC									
Output Pulses	• Litres/pulse								
	• Gallons/pulse								
MINIMUM FLOWRATE CUTOFF									
Min. flow	• Litres/sec								
	• Gallons/sec								
MAXIMUM FLOWRATE CUTOFF									
Max. flow	• Litres/sec								
	• Gallons/sec								
MAXIMUM BATCH LIMIT									
Dose Limit	• total Litres								
	• total Gallons								
MAXIMUM BACKFLOW									
	• Litres								
	• Gallons								
Comparator difference %									
Start Delay (seconds)									
Stop Delay (seconds)									
Max Output Rate (Hz)									

Date Programmed : _____ Date Commissioned : _____
 By : _____ By : _____
 Comments : _____

ME2008 - Technical Guide

Lightning and Power Supply to ME2008

- The Power Supply must come from the computer supply, which should have lightning arrestors already fitted to its Uninterruptable Power Supply (UPS).
- Fitting a 0.03 to 0.1µF 250vac capacitor on the pump contactor coil (between pump drive of ME2008 and Neutral), helps eliminate any voltage spikes (see Figure 3 on Page 13).

STARTS DRIVES

Computer starts have Black Optos which are usually solid state optos. When computer starts, the Optos stay on ("240vac energized") for the duration of the batch cycle and turn off at completion of the batch cycle. When the optos turn off, sometimes a higher than normal residual leakage voltage is maintained e.g. 90 vac (so installers/maintainers must measure, on the batching computer, the leakage voltage, when a batch is NOT in progress, between each black Opto's start 240v Active and Neutral). This voltage is sometimes enough to keep ON relays that drive contactors or solenoid coils. If this occurs, fit a 12kΩ 5W resistor between the Start Drive and Neutral connections (see Figure 3 on Page 13).

Pulse Output

In software version V1.7, the pulse output drive to the PLC optos is kept low when there are no output pulses, to help prevent noise. In V1.8, is as above, but also with ability to select a single counter for each flowmeter (so no need to bridge 1A and 1B, etc). Any units with software versions at 1.6 or earlier, should have their modules returned to ManuFlo to be upgraded to V1.7 or V1.8.

Comparator Function Explained

The reason for using 2 flowmeters per admix line is to have a double safety system against possible overdoses (as used in Hong Kong). Comparator flowmeters should be installed within 3 metres of each other.

In the event of one flowmeter malfunctioning in any way, the other flowmeter will operate as normal and the ME2008 will warn the operator of any unusual discrepancy between the two meters. Examples of possible flowmeter malfunctions include: clutching or jamming of measuring chamber due to foreign particle contamination; clutching of flowmeter due to broken components; excessive wear affecting accuracy tolerances of opposing measuring chambers; electronic pulse failure or intermittent or excessive counts.

The ME2008 Comparator function is calculated by a mathematical algorithm applied to the flowrate in order to produce a stable display and calculate difference between the two flowmeters. If flowmeter A1 is the principle flowmeter, then if it flows slower than flowmeter A2, the ME2008 will stop the batch, alarm will sound and LCD display will indicate "LOW FLOW". If flowmeter A2 flows slower than meter A1, then ME2008 will stop the batch, alarm will sound and LCD indicates "DIFFERENCE".

As a general rule, between the two LCD total displays for A1 and A2, the display that shows the higher volume is generally the correct one. To make sure, conduct a volumetric calibration test of 1 Litre. Then compare with the ME2008 displays for that admixture - the display which differs most from the actual value is the faulty flowmeter. NOTE: safety features are such that even using one flowmeter provides a fail safe system.

In MES-series meters, movement of liquid through the measurement chamber causes a disc to nutate/wobble. A known and precise volume of liquid is measured through the chamber, and movement information is transmitted via a contact free drive assembly to the electronic head which generates pulses transmitted back to the ME2008. **Number of pulses is proportional to flow: 1 pulse = 1 millilitre (for a 20mm MES20 flowmeter)**. If the measurement chamber becomes worn overtime (mainly due to excessive impurities passing through the chamber), the proportion of pulses representing volume will change.

Warnings on ME2008 display – SOLUTION GUIDE

- | | | |
|--|---|--|
| "Low Flow" (alarm sounds) | = | Pulse fail (missing pulses due to flowmeter jamming, airlock in delivery line, pulse cable problem etc). |
| "High Flow" (alarm sounds) | = | High flow above setting (flowmeter running over max. set flowrange velocity). |
| "Output Overrun" | = | Higher pulse rate than pulse out Hz (frequency) maximum setting. |
| "Overdose" | = | Limit exceeded on setting during batch. |
| "Backflow" | = | There is flow of liquid after a batch completes. Possible causes:
* Faulty check valve;
* The contactor to the pump is stuck on;
* Excessive vibration at the flowmeter, which may be causing spurious pulses.
See also TROUBLESHOOTING - BACKFLOW on next page. |
| "Diff Flow" | = | When using dual flowmeters, excessive difference between the meters indicates that a meter is faulty; |
| "Settings Lost"
(or frozen display condition) | 1 | Dirty electricity power supply problem or severe industrial spikes/noise.
The computer system has a Uninterruptable Power Supply (UPS), it is better that the ME2008's power supply comes from the UPS, and not from other 240vac 2 nd phases. |
| | 2 | Sometimes spiking contactor coils in close proximity to ME2008 can cause interference. Fitting 0.01 to 0.03µF 250 vac capacitors on the pump contactor coils (between Neutral and the R1 pin of the DCM black X1 plug) helps eliminate spikes (see Figure 3 on Page 13). |
| | 3 | To re-enable the module showing "settings lost", proceed as follows:
• Plug the hand-held Programmer into the Dual Channel Module;
• To restore the default settings (which are input calibration 1000 pulses/Litre, divided pulse output 10mls/pulse), push 2 buttons simultaneously on the Programmer, being either the 2 arrow buttons or the DOWN and UP buttons;
• Re-enter parameters (via the Programmer) and refer to program sheet settings. |
| | 4 | If the software version is earlier than V1.7, then return module(s) to ManuFlo for software upgrade. |

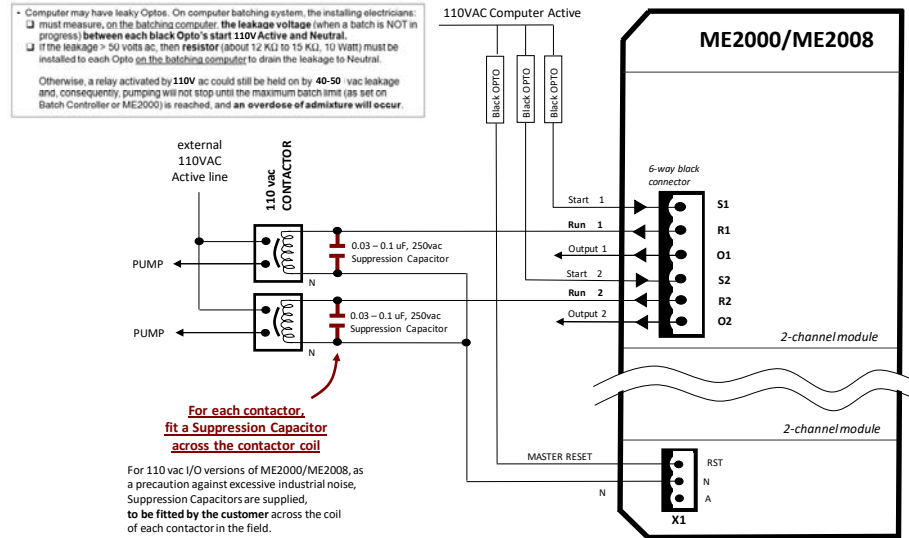

Figure 3. Fitting Suppression Capacitors to prevent electrical noise, and Resistors to prevent voltage leakage.

TROUBLESHOOTING - BACKFLOW

In some installations with standard MES flowmeters, the ME2008 may count without batching being in progress, causing a "Back Flow" alarm.

- 1 Usually, this is due to the Non-Return Valve not closing, thus allowing backflow which results in counts as the liquid runs back thru the flowmeter (PD types).
Ensure that the Non-Return Valve is clean and operating correctly.
- 2 If Non-Return Valve is OK, then ensure that shielded cable is used. If cable is not shielded, then interference can be picked up and transmitted to the ME2008 which will interpret it as backflow.
- 3 If shielding is OK, then possible cause is vibration in plant near MES meters. Install flowmeters away from vibration causes, or anchor meters with rubber mounts.
- 4 If after batch complete and the **shut off valve fails** to close, then "backflow" alarm will engage.
- 5 If vibration is still prevalent, then using MES-R Reed Switch flowmeter pulseheads is recommended.
 - The **MES-R pulsehead is GREEN in colour with a square junction box** (2 wire connection) - this distinguishes them from the ordinary MES black/white round junction pulseheads.
 - The MES-R pulsehead is **much less sensitive to vibration**, having much higher hysteresis.

See installation and programming instructions below, in particular that reprogramming of the ME2008 is required because an MES20-R 20mm size gives 61 pulses/Litre instead of 1000 pulses/Litre.

New MES-N pulseheads with new all solid state smart technology (frwd/ivrse flow) are vibration free and interchangeable with old style pulseheads.

MES-R INSTALLATION and PROGRAMMING

- A Replace MES pulsehead with an MES-R pulsehead.
- B. Wire "Shield" and "Pulse" connections only. This is a 2-wire connection only - DO NOT wire +12v into pulsehead.
- C. Program the ME2008 Input Pulse to following factors:
for MES20-R 20mm : 0061.00 pulses/Litre, for MES25-R 25mm : 0034.00 pulses/Litre
All other program factors remain unchanged.
- D. **VERY IMPORTANT**
After replacement and programming of pulsehead, take a calibration test before you leave the plant.

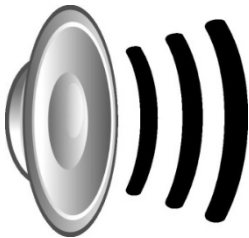

ME2008 DISPENSER INTERFACE IN CASE OF ALARM WARNING:-

- If any of the safety features are triggered, the alarm will sound.
- The Display will indicate message status condition of the channel that is in alarm condition, as a precaution the ME2008 will shut down pump drive of the faulty channel only, allowing further examination of the problem.

- **DO NOT** push RESET immediately - observe display and take note of the batch readings and the alarm message.
- **WAIT** for other channels to complete batch, then push RESET to be ready for the next batch.
- If batcher gets an Alarm again at batching, then:
 - **MOVE THE TRUCK MIXER AWAY FROM THE LOADING POINT**
 - o stop using that chemical channel; as each attempt doses 2 seconds worth of chemical into the mix.
 - o record the quantity displayed on the ME2008 and the batch computer; and ring your local admixture supplier for advise/service.

Interface – ME2000/2008

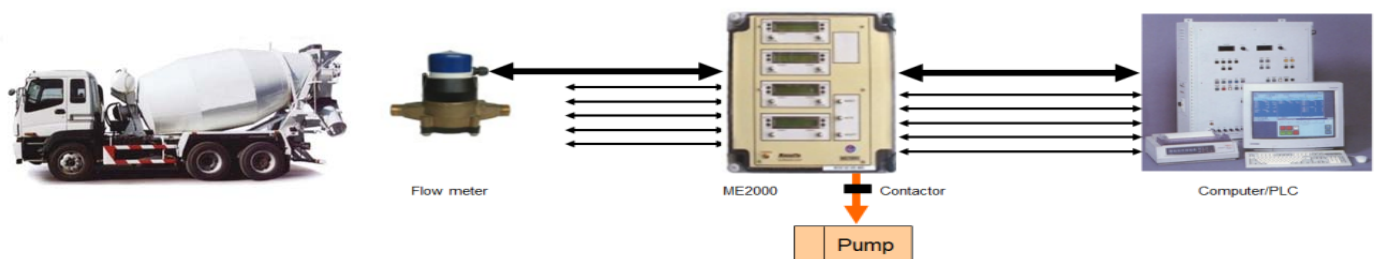

If in doubt, contact ManuFlo on phone +61 2 9938 1425 or +61 2 9905 4324.

ManuFlo®™

Flow Measurement Products

ABN: 47-002-946-303

a division of

MANU ELECTRONICS PTY LTD

41 Carter Road, Brookvale
Sydney NSW 2100 Australia

Ph: + 61 2 9938 1425, 9905 4324

Fax: + 61 2 9938 5852

Web: www.manuelectronics.com.au

Email: sales@manuelectronics.com.au

Rev : 1306/2