

FEATURES:

- ◆ For grout, oxides, silicafume, recycle-water & selected slurry applications (upto 50% solids).
- ◆ Polypropylene liner, Hastelloy C electrodes, ANSI 150 lb Flanges
- ◆ K-MAGS Fully wired and custom programmed.
- ◆ Flow sensor sizes 25 to 150mm
- ◆ Flanged connection suites ANSI 150lb flanges
- ◆ Self-verifying. Accuracy: $\pm 0.2\%$.
- ◆ Totaliser up to 10 digits. With Flowrate display.
- ◆ Integral display or Remote via 2-metres cable to flowsensor.
- ◆ Durable cast alloy display box (integral) or plastic (remote).
- ◆ Pulse and 4-20mA outputs. HART protocol.
- ◆ Programmable via reflective buttons or via HART to
- ◆ Built in flow profiler for higher accuracy
- ◆ IP68 remote flow sensor (when potted).
- ◆ Empty pipe detection.
- ◆ Pressure rating to 1600 kpa:
- ◆ Process temperature: $-5\text{ }^{\circ}\text{C}$ to $90\text{ }^{\circ}\text{C}$
- ◆ Measured liquid must have conductivity of at least $1\text{ }\mu\text{S/cm}$ ($20\mu\text{S/cm}$ for water)
- ◆ 85 - 253 vac or 11 – 31 vdc powered



The **K-MAGS** electromagnetic flowmeters are custom configured, wired, programmed, tested and supplied by *ManuFlo*. They offer quality performance with accuracy of $\pm 0.3\%$ of rate and are capable of operating over very wide flow ranges. With no moving parts and an obstruction-less bore, this type of flowmeter guarantees the highest level of performance, unaffected by specific gravity or viscosity variations, or the most contaminated of fluids, whilst maintaining a high degree of accuracy for liquids with conductivity $\geq 5\mu\text{S/cm}$. A unique self-verifying feature is implemented in K-mags, providing ultra-stable performance over time.

All K-MAGS are supplied fully wired, programmed to your specific application requirements, and tested, with Total and Flowrate display and outputs all configured. Application examples include use for measuring mining slurries, grouts, oxides, construction chemicals, food industry etc. The uses are wide and far reaching.

Size (mm)	Order Code	MINIMUM Flowrate		MAXIMUM Flowrate
	Integral	(Litres/minute) @ $\pm 1\%$ accuracy *	(Litres/minute) @ $\pm 0.2\%$ accuracy	(Litres/minute) @ $\pm 0.2\%$ accuracy
25	KMS302P-25F	4	30	330
40	KMS302P-40F	11	75	905
50	KMS302P-50F	14	80	1413
80	KMS302P-80F	31	150	3619
100	KMS302P-100F	56	250	5655
150	KMS302P-150F	83	1050	10500

* will measure at lower flowrates, but at reduced accuracy.

OPTIONS

-R	Remote wired display/transmitter w/ 2m cable	-DC	11-31 VDC Powered
-TRB	Totaliser Reset Button	-XCn	Extra cable (where n = extra cable length in metres)
-VR	Virtual Reference grounding option for IFC 300 (instead of grounding rings on corrosive media)		
ANSI-150 PVC or Galvanized Iron connection kits available			

Signal converter / Display	
Design	Remote version Integral version
Outputs	4-20mA & Pulse output
Input	External totaliser reset input
Counter	2 internal counter, 10 digits max
Verification	Integrated verification Diagnostic functions Empty Pipe detection
Comms interface	HART®
Graphic display	59 x 31 mm white backlit LCD
Operating elements	4 Optical keys
Units	Totaliser L; mL; m ³ ; gal Flowrate L/sec; L/min; L/h; m ³ /h; gal/min
Protection category	IP65
Materials	Remote Polyamide - polycarbonate Integral Aluminium (polyurethane coated)
Power supply	85 – 253 VAC @ 22 VA 11 – 31 VDC @ 12 W
Signal cable	2 metres standard (Remote version only)
Cable entries	M20 x 1.5 (8...12mm)

Measuring sensor / Tube	
Accuracy	±0.2% @ 1 mm/s
Repeatability	±0.1%
Temperature	-5 to 90 °C
Pressure rating	≤ 1600 kpa
Conductivity	Water: ≥ 20 µS/cm Other media: ≥ 1 µS/cm
Solid content (volume)	≤ 50%
Protection category	IP65 or IP68 when potted
Materials	Liner: Polypropylene liner Electrodes: Hastelloy C Housing: Sheet steel
Cable entries	M20 x 1.5 (8...12mm)

Basic Input and Outputs (I/Os)	
Analog 4-20mA Output	Active: R _L ≤ 1kΩ @ I ≤ 22mA Passive: U _{ext} ≤ 32VDC; I _s ≤ 22mA
Digital Pulse Output	Passive: U _{ext} ≤ 32VDC; I _s ≤ 100mA
Pulse rate	0.25 to 10KHz
Pulse width	Symmetric (50% duty cycle) Fixed (0.05 up to 2000mS)
Totaliser Reset Input	Passive: 12 – 32 VDC

DISPLAY AND OPERATING ELEMENTS

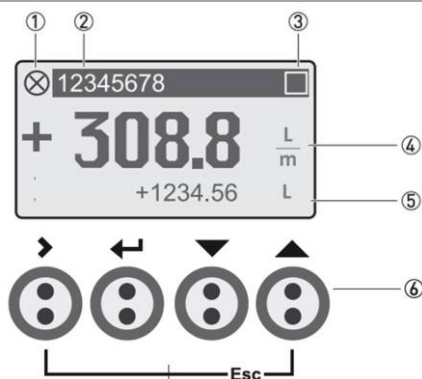

Display example:

Flow indication in Litres per minute (L/m) and totaliser in Litres (L)

- (1) Indicates a possible status message in the status list
- (2) Tag number (is only indicated if this number was entered previously by the operator)
- (3) Indicates when a key has been pressed
- (4) Flowrate in large representation
- (5) Forward totalizer
- (6) Optical keys for accessing menu and settings

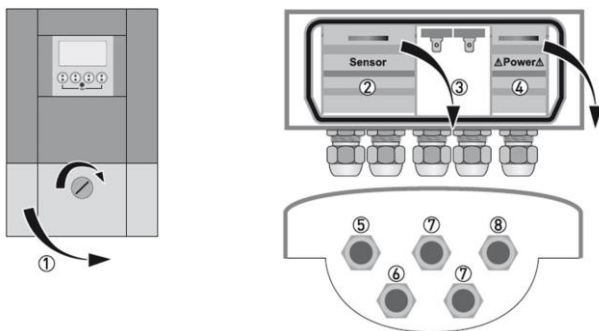

Remote display version:

Electrical connection to the measuring sensor via field current and signal cable (standard 2 metres cable)

- (1) Cover for terminal components
- (2) Terminal compartment for measuring sensor
- (3) Terminal compartment for inputs and outputs
- (4) Terminal compartment for power supply w/ safety cover
- (5) Cable entry for field current and signal cable
- (6) Cable entry for inputs and outputs
- (7) Cable entry for inputs and outputs/totalizer reset button
- (8) Cable entry for power supply input (AC or DC) version

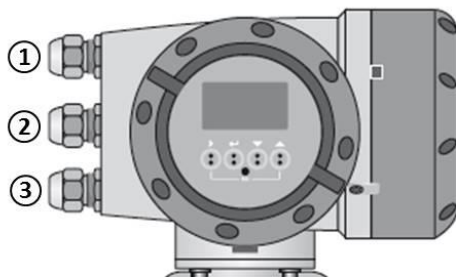

Integral display version:

- (1) Cable entry for power supply input (AC or DC) version
- (2) Cable entry for inputs and outputs/totalizer reset button
- (3) Cable entry for inputs and outputs....

DANGER! The device must be grounded in accordance with regulations in order to protect personnel against electric shocks.
CAUTION! Observe connection polarity

① PE

② FE

Power supply connection

(1) 85 – 253 VAC @ 22 VA
(2) 11 – 31 VDC @ 12 W

- ◆ Terminal compartment for power supply w/ safety cover

Current output active (HART®)

- $U_{int, nom} = 24 \text{ VDC}$
- $I \leq 22 \text{ mA}$
- $R_L \leq 1 \text{ k}\Omega$
- HART® at connection terminals A

Current output passive (HART®)

- $U_{int, nom} = 24 \text{ VDC}$
- $U_{ext} \leq 32 \text{ VDC}$
- $I \leq 22 \text{ mA}$
- $U_0 \geq 1.8 \text{ V}$ at $I = 22 \text{ mA}$
- $R_L \leq (U_{ext} - U_0) / I_{max}$
- HART® at connection terminals A

Pulse output passive (standard)

- $U_{ext} \leq 32 \text{ VDC}$
- f_{max} in operating menu set to $100 \text{ Hz} < f_{max} \leq 10 \text{ kHz}$:
(over range up to $f_{max} \leq 12 \text{ kHz}$)
 $I \leq 20 \text{ mA}$
 $R_L \leq 10 \text{ k}\Omega$ for $f \leq 1 \text{ kHz}$
 $R_L \leq 1 \text{ k}\Omega$ for $f \leq 10 \text{ kHz}$
closed:
 $U_0 \leq 5 \text{ V}$ at $I = 20 \text{ mA}$
open:
 $I \leq 0.05 \text{ mA}$ at $U_{ext} = 32 \text{ V}$
- The minimum load impedance R_L, min is calculated as follows: $R_L, min = (U_{ext} - U_0) / I_{max}$
- The output is open if the device is de-energised.

Laying electrical cables correctly

- (1) For compact versions with nearly horizontally-oriented cable entries, lay the necessary electric cables with a drip loop as shown in the illustration.
- (2) Tighten the screw connection of the cable entry securely.
- (3) Seal cable entries that are not needed with a plug.

INTEGRAL Version

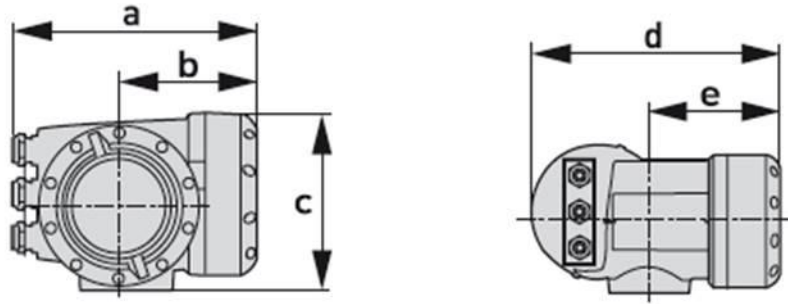

Version	Dimensions [mm]					Weight [kg]
	a	b	c	d	e	
Integral	202	120	155	260	137	4.2

REMOTE Version

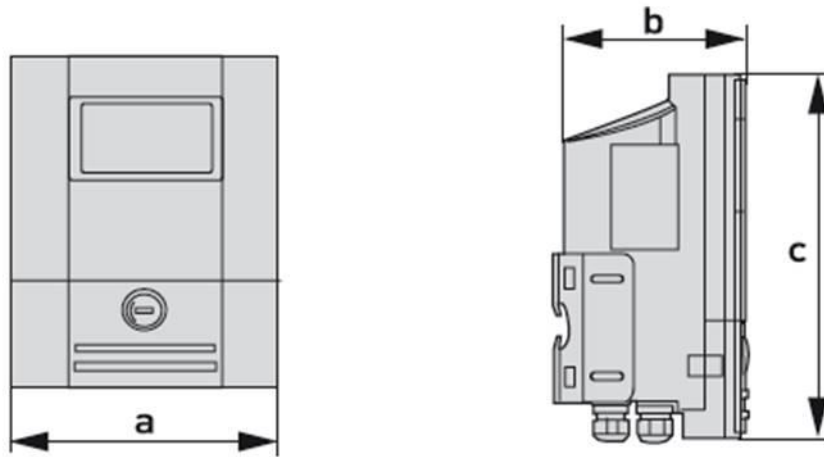

Version	Dimensions [mm]					Weight [kg]
	a	b	c	d	e	
Remote	198	138	299	-	-	2.4

Mounting Plate, wall-mounted housing

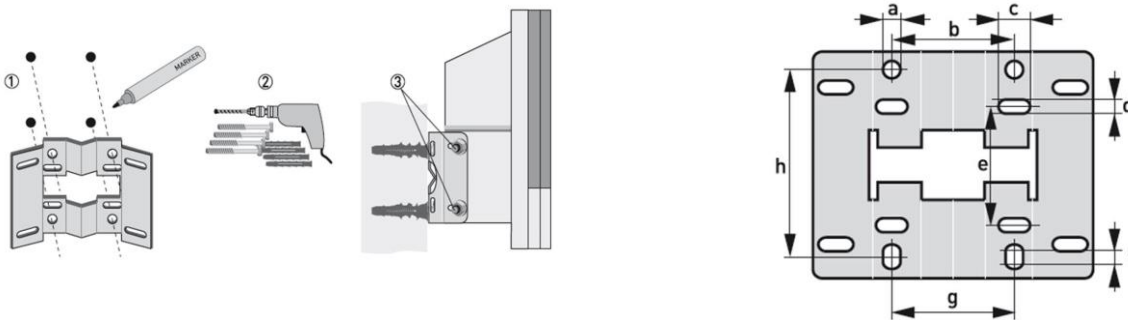

[mm]	a	b	c	d	e	f	g	h
	9	64	16	6	63	4	64	98

REMOTE Version DN25 to 150mm

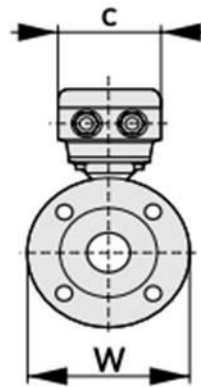
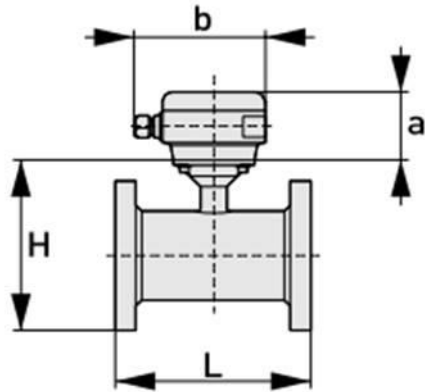

a = 88 mm
 b = 139 mm
 c = 106 mm
 Total height = H + a

INTEGRAL Version DN25 to 150mm

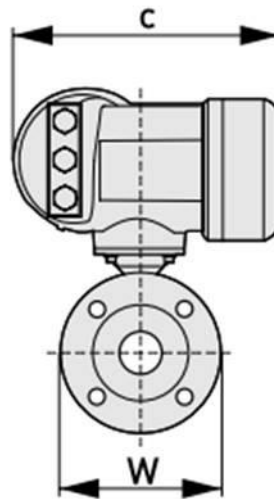
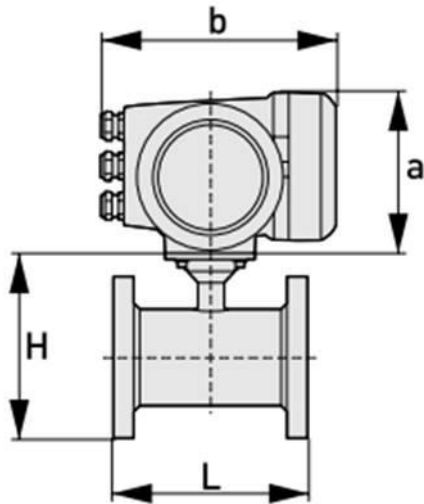

a = 155 mm
 b = 230 mm
 c = 260 mm
 Total height = H + a

Nominal size DN [mm]	Dimensions [mm]				Approx. weight [kg]
	Standard length	ISO Insertion length	H	W	
25	150	200	140	115	5
40	150	200	166	150	7
50	200	200	186	165	11
80	200	200	209	200	14
100	250	250	237	220	15
150	300	300	300	285	27

Straight Pipe Requirements

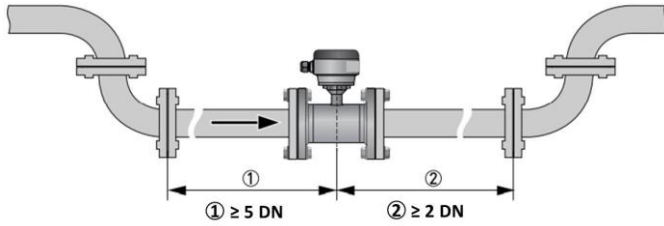

To ensure accurate measurement:

- Pipe must be full at all times
- Must have straight pipe of length > 5x pipe diameter upstream of sensor and also straight pipe of length > 2x pipe diameter downstream of sensor.

e.g. 50mm flowmeter requires

at least 250mm of straight 50mm Ø pipe upstream, and at least 100mm of straight 50mm Ø pipe downstream

Installation on bending pipes

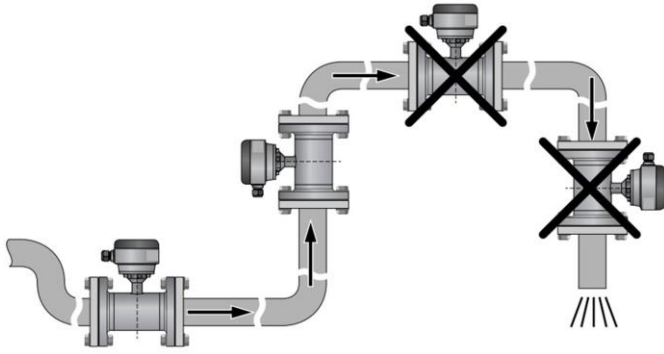

Air venting

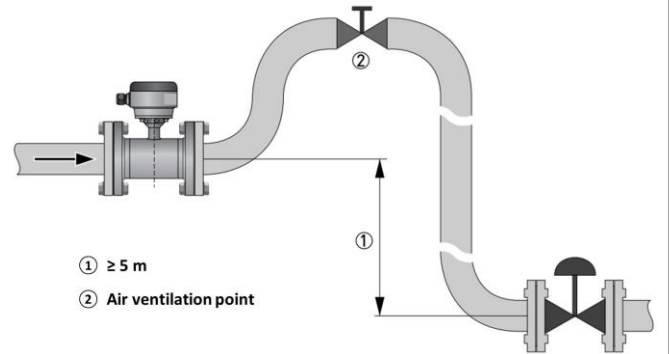

T - section

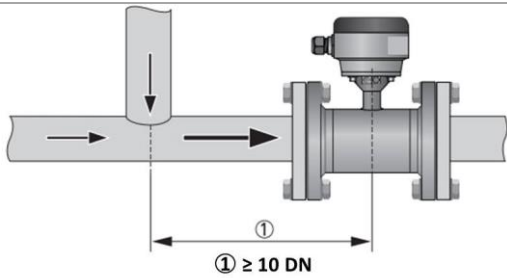

Installation in front of an open discharge

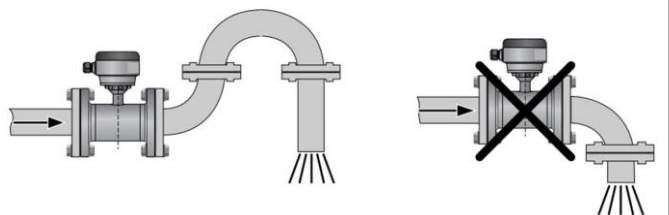

Installation behind a pump

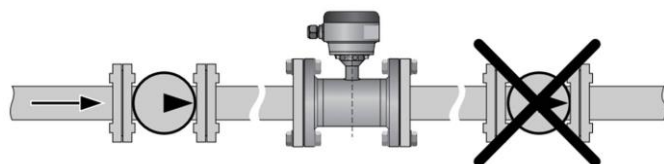

Installation in front of a control valve

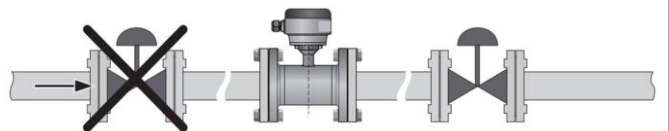

Avoid vibrations and magnetic field

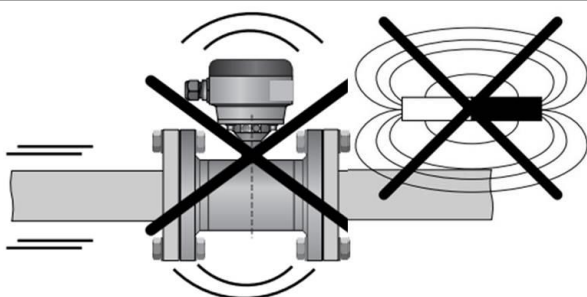

Grounding

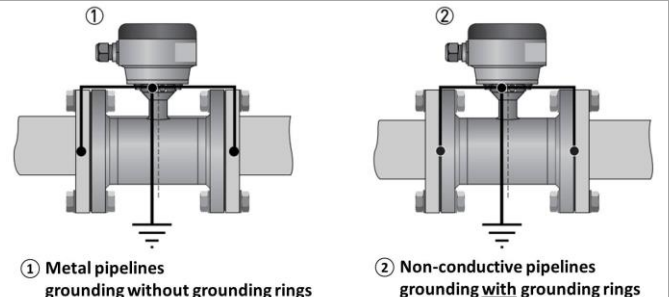

KMS Electromagnetic Flowmeter Installation Guide and Checklist

<u>LOCATION</u>	
To avoid vibration that may hinder correct flow readings, support the weight of the flowmeter sensor.	<input type="checkbox"/>
Mount the flowmeter's display box in an area that allows easy access for reading.	<input type="checkbox"/>
If mounted outdoors: <ul style="list-style-type: none"> • Install a sunshade, to protect the display box from direct sunlight; and • Consider if you need to install a lockable vandal-proof enclosure, preferably with a window for reading the display. 	<input type="checkbox"/>
To ensure correct flow readings, avoid installing the flowmeter sensor in the vicinity of strong electromagnetic fields , and avoid areas where there is excessive vibration .	<input type="checkbox"/>
Ensure that the chosen location will allow the flowmeter to operate within its environmental rating .	<input type="checkbox"/>
<u>ELECTRICAL</u>	
Have the appropriate power supply (e.g 85-253vac or 11 -31 VDC) available.	<input type="checkbox"/>
Units in most cases come prewired between sensor and transmitter/display box, otherwise ensure proper colour coding is used when wiring signal cable.	<input type="checkbox"/>
If unsure regarding wiring of outputs – call ManuFlo. Use cable glands provided and make sure they are properly tightened and sealed. Allow for a drip loop before the gland to prevent ingress into the transmitter.	<input type="checkbox"/>
<u>PLUMBING</u>	
Install the flowmeter sensor in a section of pipe that is full at all times , to ensure correct flow readings.	<input type="checkbox"/>
To prevent turbulence in the flow that may hinder correct flow readings, ensure that there is straight pipe before and after the sensor , of length at least: <ul style="list-style-type: none"> • 5x pipe diameter before (upstream of) sensor; and • 2x pipe diameter after (downstream of) sensor. e.g. for 50mm diameter pipe, the lengths of straight pipe required are at least 5x50mm=250mm before sensor, and 2x50mm=100mm after sensor.	<input type="checkbox"/>
Install any gaskets and bonding cables according to the type of pipe.	<input type="checkbox"/>

Note: detailed installation instructions are in the Manual provided with the flowmeter.

Due to continuous product improvement, specifications are subject to change without notice.

